

CBSE Class 10 Mathematics

Important Questions

Chapter 13

Problems Based on Conversion of Solids

1. A solid is in the form of a right circular cone mounted on a hemisphere. The radius of the hemisphere is 3.5 cm and the height of the cone is 4 cm. The solid is placed in a cylindrical tub, full of water, in such a way that the whole solid is submerged in water. If the radius of the cylindrical tub is 5 cm and its height is 10.5 cm, find the volume of water left in the cylindrical tub. use  $\pi = 22/7$

Ans: No. of solid = vol of cone + vol of hemisphere

$$= \frac{1}{3}\pi r^2 h + \frac{2}{3}\pi r^3$$

$$= \frac{1}{3}\pi r^2 h [h + 2r]$$

On substituting we get,

$$= 141.17 \text{ cm}^3$$

$$\text{vol of cylinder} = \pi r^2 h$$

On substituting we get,

$$= 825 \text{ cm}^3$$

$$\text{volume of H}_2\text{O left in the cylinder} = 825 - 141.17$$

$$= 683.83 \text{ cm}^3$$

2. A bucket of height 8 cm and made up of copper sheet is in the form of frustum of right circular cone with radii of its lower and upper ends as 3 cm and 9 cm respectively. Calculate
- the height of the cone of which the bucket is a part
  - the volume of water which can be filled in the bucket
  - the area of copper sheet required to make the bucket (Leave the answer in terms of  $\pi$ )

Ans: Let total height be h

$$\Rightarrow \frac{h}{h+8} = \frac{3}{9} (\text{similar } \Delta' s)$$



$$\Rightarrow h = 4 \text{ cm}$$

$\therefore$  ht. of cone which bucket is a part = 4 cm

Substitute to get Ans.: for ii) iii) 97

3. **A sphere and a cube have equal surface areas. Show that the ratio of the volume of the sphere to that of the cube is  $\sqrt{6} : \sqrt{\pi}$ .**

Ans: S.A. of sphere = S.A of cube

$$\Rightarrow 4\pi r^2 = 6a^2$$

$$\Rightarrow r = \sqrt{\frac{6a^2}{4\pi}}$$

$$\therefore \text{ratio of their volume } \frac{v_1}{v_2} = \frac{\frac{4}{3}\pi r^3}{a^3}$$

On simplifying & substituting, we get  $\sqrt{6} : \sqrt{\pi}$

4. **A right triangle whose sides are 15 cm and 20 cm is made to revolve about its hypotenuse. Find the volume and surface area of the double cone so formed.**

$$\text{Ans: } BC = \sqrt{15^2 + 20^2} = 25 \text{ cm}$$

Apply Py. Th to right  $\Delta$  OAB & OAC to get OB = 9cm OA = 12cm

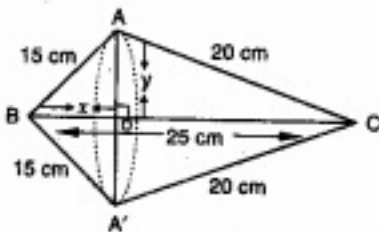

$$\text{Vol of double cone} = \text{vol of } CAA^1 + \text{vol of } BAA^1$$

$$= \frac{1}{3}\pi \times 12^2 \times 16 + \frac{1}{3}\pi \times 12^2 \times 9$$

$$\text{SA of double cone} = \text{CSA of } CAA^1 + \text{CSA of } BAA^1$$

$$= \pi \times 12 \times 20 + \pi \times 12 \times 15$$

$$= 1318.8 \text{ cm}^3$$

5. **Water in a canal 30 dm wide and 12 dm deep is flowing with a velocity of 10 km/h. How much area will it irrigate in 30 minutes if 8 cm of standing water is required for irrigation?**

Ans: Width of canal = 30 dm = 3m

Depth of canal = 1.2 m

Velocity = 10 km / h = 10000 m/h

Length of water column is formed in 30 min =  $10000 \times \frac{1}{2} = 5000m$

Let  $xm^2$  of area be irrigated  $\Rightarrow x \times \frac{8}{100} = 5000 \times 1.2 \times 3$

$\Rightarrow x = 225000 m^2$

6. **A cylindrical vessel of diameter 14 cm and height 42 cm is fixed symmetrically inside a similar vessel of diameter 16 cm and height 42 cm. The total space between two vessels is filled with cork dust for heat insulation purposes. How many cubic centimetres of cork dust will be required?**

Ans: volume of cork dust required =  $\pi R^2h - \pi r^2h$

$$= \pi 42 [ 64 - 49]$$

$$= 1980 \text{ cm}^3$$

7. **A building is in the form of a cylinder surrounded by a hemispherical vaulted dome and contains  $41 \frac{19}{21}$  cu m of air. If the internal diameter of the building is equal to its total height above the floor, find the height of the building.**

Ans: Volume of building =  $41 \frac{19}{21} m^3$

$$\Rightarrow \pi \cdot r^2 \cdot r + \frac{2}{3} \pi r^3 = 41 \frac{19}{21}$$

$$\Rightarrow \pi \times r^3 \times \frac{5}{3} = \frac{880}{21}$$

$$\Rightarrow r^3 = \frac{880}{21} \times \frac{7}{22} \times \frac{3}{5}$$

$$\Rightarrow r^3 = 8$$

$$\Rightarrow r = 2m$$

$\therefore$  height of building = 4 cm

8. **The height of the Cone is 30 cm A small cone is cut of f at the top by a plane parallel to its base if its volume be  $\frac{1}{27}$  of the volume of the given cone at what height above the base is the section cut.**

Ans:  $\Delta VO^1B \sim \Delta VOB$

$$\therefore \frac{H}{h} = \frac{R}{r} = \frac{30}{h} = \frac{R}{r} \dots\dots (1)$$

APQ: vol of cone  $VA^1B^1 = \frac{1}{27}$  (vol of cone VAB)



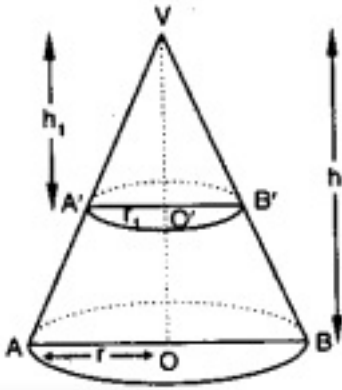

$$\Rightarrow \frac{1}{3} \pi r^2 h = \frac{1}{27} \left( \frac{1}{3} \pi R^2 H \right)$$

$$\Rightarrow h^3 = 1000 \text{ (using (1))}$$

$$h = 10 \text{ cm}$$

$\therefore$  height at which section is made  $(30 - 10) = 20 \text{ cm}$

9. A hollow cone is cut by a plane parallel to the base and the upper portion is removed. If the curved surface of the remainder is  $\frac{8}{9}$  th of the curved surface of the whole cone, find the ratio of the line segments into which the cone's altitude is divided by the plane.

Ans. We know that  $\Delta VO'B \sim \Delta VOB$

$$\frac{h}{H} = \frac{r}{R} = \frac{l}{L}$$

$$C. \text{ SA of frustum} = \frac{8}{9} \text{ (CSA of the cone)}$$

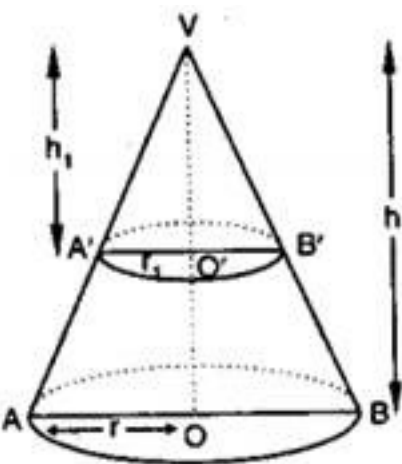

$$\Rightarrow \left( \frac{R+r}{R} \right) \left( \frac{L-l}{L} \right) = \frac{8}{9}$$

$$\Rightarrow \left( 1 + \frac{r}{R} \right) \left( 1 - \frac{l}{L} \right) = \frac{8}{9}$$

$$\Rightarrow \left( 1 + \frac{h}{H} \right) \left( 1 - \frac{h}{H} \right) = \frac{8}{9}$$

On simplifying we get  $\frac{h^2}{H^2} = \frac{1}{9}$

$$\frac{h}{H} = \frac{1}{3}$$

$$\Rightarrow H = 3h$$

$$\text{required ratios} = \frac{h}{H-h} = \frac{1}{2}$$

10. **Two right circular cones X and Y are made X having 3 times the radius of Y and Y having half the Volume of X. Calculate the ratio of heights of X and Y.**

**Ans:** Let radius of cone X = r

Radius of Cone Y = 3r

V of Y =  $\frac{1}{2}$  volume of X

$$\frac{1}{3} \pi r^2 h_1 = \frac{1}{2} \left( \frac{1}{3} \pi r^2 h_2 \right)$$

$$\Rightarrow r^2 h_1 = \frac{1}{2} 9r^2 h_2$$

$$\frac{h_1}{h_2} = \frac{9r^2}{2r^2}$$

$$\frac{h_1}{h_2} = \frac{9}{2}$$

11. **If the areas of three adjacent faces of cuboid are x, y, z respectively, Find the volume of the cuboids.**

Ans: lb = x, bh = y, hl = z

Volume of cuboid = lbh

$$V^2 = l^2 b^2 h^2 = xyz$$

$$V = \sqrt{xyz}$$

12. **A shuttlecock used for playing badminton has the shape of a frustum of a Cone mounted on a hemisphere. The external diameters of the frustum are 5 cm and 2 cm, and the height of the entire shuttlecock is 7cm. Find the external surface area.**

Ans:  $r_1$  = radius of lower end of frustum = 1 cm

$r_2$  = radius of upper end = 2.5 cm

h = ht of frustum = 6cm

$$l = \sqrt{h^2 + (r_2 - r_1)^2} = 6.18 \text{ cm}$$

$$\text{External surface area of shuttlecock} = \pi(r_1 + r_2)l + 2\pi r_1^2$$

On substituting we get, = 74.26 cm<sup>2</sup>



13. A conical vessel of radius 6cm and height 8cm is completely filled with water. A sphere is lowered into the water and its size is such that when it touches the sides, it is just immersed as shown in the figure. What fraction of water flows out.

**Ans:** This problem can be done in many ways

Let "r" be the radius of sphere

In right triangle

$$\tan \theta = \frac{6}{8} = \frac{3}{4}$$

$$\Rightarrow \sin \theta = \frac{3}{5}$$

in rt  $\Delta$

$$\sin \theta = \frac{r}{VO} = \frac{3}{5} = \frac{r}{8-r}$$

$$r = 3 \text{ cm}$$

Volume of H<sub>2</sub>O that flows out of cone = volume of sphere

$$\begin{aligned} \text{fraction of water Overflows} &= \frac{\text{volume of sphere}}{\text{Volume of cone}} \\ &= \frac{36\pi}{96\pi} = \frac{3}{8} \end{aligned}$$

14. A golf ball has a diameter equal to 4.1cm. Its surface has 150 dimples each of radius 2mm. Calculate the total surface area which is exposed to the surroundings assuming that the dimples are hemispherical.

$$\text{Ans: SA of ball} = 4\pi \times \left(\frac{4.1}{2}\right)^2 = 16.8 \pi \text{ cm}^2$$

TSA exposed to surroundings

$$= \text{SA of ball} - 150 \times \pi r^2 + 150 \times 2\pi r^2$$

$$= 16.8\pi + 150 \pi r^2$$

$$= 71.68 \text{ cm}^2$$

15. A solid metallic circular cone 20 cm height with vertical angle 60 is cut into two parts at the middle point of its height by a plane parallel to the base. If the frustum, so obtained be drawn into a wire of diameter  $\frac{1}{16}$  cm Find the length of the wire.

**Ans:** Let  $r_1$  &  $r_2$  be the two ends of the frustum  $\frac{r_1}{20} = \tan 30$

$$r_1 = \frac{20}{\sqrt{3}}; r_2 = \frac{10}{\sqrt{3}} \text{ cm}$$

$$\text{volume of frustum} = \frac{1}{3} \pi h (r_1^2 + r_2^2 + r_1 r_2)$$

$$= \frac{1}{3}\pi \times 10 \left( \frac{400}{3} + \frac{100}{3} + \frac{200}{3} \right) cm$$

Since the frustum is drawn into a wire of length x

Volume of frustum = volume of cylinder

$$\frac{1}{3}\pi \times 10 \times \frac{700}{3} = \pi \left( \frac{1}{32} \right)^2 \times x$$

$$\Rightarrow x = \frac{7168000}{9} cm$$

$$x = 7964.4m$$

16. The lower portion of a hay stack is an inverted cone frustum and the upper part is a cone find the total volume of the hay stack.

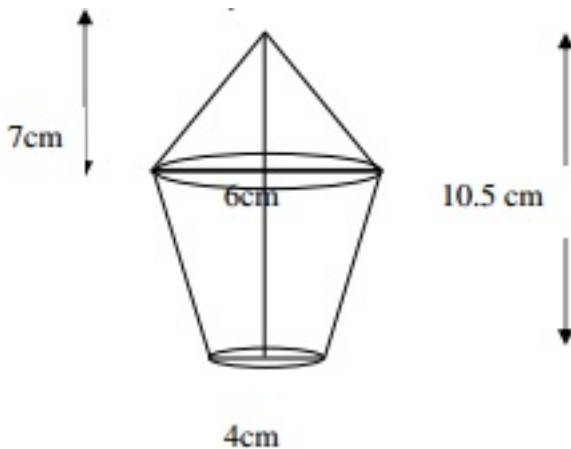

17. A vessel in shape of a inverted cone is surmounted by a cylinder has a common radius of 7cm this was filled with liquid till it covered one third the height of the cylinder. If the height of each part is 9cm and the vessel is turned upside down. Find the volume of the liquid and to what height will it reach in the cylindrical part.

**Ans:** Volume of liquid in the vessel =  $\frac{1}{3}(7)^2(9) + \pi(7)^2(3)$

$$= 924 \text{ cu cm}$$

$$\text{height of cylindrical part} = \frac{924}{\frac{22}{7} \times 49} = 6cm$$

**CBSE Class 10 Mathematics**  
**Important Questions**  
**Chapter 13**  
**Surface Areas and Volumes**

**1 Marks Questions**

1. A metallic sphere of radius 10.5cm is melted and then recast into small cones each of radius 3.5cm and height 3cm, the number of such cones is

- (a) 63
- (b) 126
- (c) 21
- (d) 130

Ans. (b) 126

2. A solid sphere of radius  $r$  is melted and cast into the shape of a solid cone of height  $r$ , the radius of the base of the cone is

- (a)  $2r$
- (b)  $3r$
- (c)  $r$
- (d)  $4r$

Ans. (a)  $2r$

3. During conversion of a solid from one shape to another, the volume of new shape will

- (a) increase
- (b) decrease





(c) remain unaltered

(d) be doubled

Ans. (c) remain unaltered

4. A right circular cylinder of radius  $r$  cm and height  $h$  cm ( $h > 2r$ ) just encloses a sphere of diameter

(a)  $r$  cm

(b)  $2r$  cm

(c)  $h$  cm

(d)  $2h$  cm

Ans. (b)  $2r$  cm

5. A solid sphere of radius  $r$  is melted and cast into the shape of a solid cone of height  $r$ , the radius of the base of the cone is

(a)  $2r$

(b)  $3r$

(c)  $r$

(d)  $4r$

Ans. (a)  $2r$

6. A reservoir is in the shape of a frustum of a right circular cone. It is 8m across at the top and 4m across at the bottom. If it is 6m deep, then its capacity is

(a)  $176 \text{ m}^3$

(b)  $196 \text{ m}^3$

(c)  $200 \text{ m}^3$

(d)  $110 \text{ m}^3$

Ans. (a)  $176 \text{ m}^3$

7. A cone of height 24 cm and radius of base 6 cm is made up of modeling clay. A child reshapes it in the form of a sphere, the radius of the sphere is

(a) 5 cm

(b) 6 cm

(c) 8 cm

(d) 12 cm

Ans. (b) 6 cm

8. A circular tent is cylindrical to a height of 4 m and conical above it. If its diameter is 210 m and its slant height is 40m. The total area of the canvas required in  $\text{m}^2$  is

(a) 1760

(b) 15840

(c) 3960

(d) 7960

Ans. (b) 15840

9. The radii of the ends of a bucket 30cm high are 21 cm and 7cm. then its capacity in litres is

(a) 19.02

(b) 20.02

(c) 21.02

(d) 19.08

Ans. (b) 20.02

10. A solid is hemispherical at the bottom and conical above it. The surface areas of the two parts are equal, then the ratio of its radius and the height of its conical part is

(a) 1:3

(b)  $1:\sqrt{3}$

(c) 1:1

(d)  $\sqrt{3}:1$

Ans. (b)  $1:\sqrt{3}$

11. The diameter of a sphere is 6cm. It is melted and drawn into a wire of diameter 2cm. The length of the wire is

(a) 12 cm

(b) 18 cm

(c) 36 cm

(d) 66 cm

Ans. (c) 36 cm

12. If the radii of the circular ends of a bucket of height 40 cm are 35cm and 14cm. Then volume of the bucket in cubic centimeters is

(a) 60060

(b) 80080



(c) 70040

(d) 80760

Ans. (b) 80080

13. The diameter of a metallic sphere is 6cm. It is melted and drawn into a wire of diameter of the cross-section 0.2cm, then the length of wire is

(a) 12 m

(b) 18 m

(c) 36 m

(d) 66 m

Ans. (c) 36 m

14. The ratio between the volumes of two spheres is 8:27. What is the ratio between their surface areas?

(a) 2:3

(b) 4:5

(c) 5:6

(d) 4:9

Ans. (d) 4:9

15. A hollow cube of internal edge 22cm is filled with spherical marbles of diameter 0.5cm and it is assumed that  $\frac{1}{8}$  space of the cube remains unfilled. Then the number of marbles that the cube can accommodate is

(a) 142296



(b) 142396

(c) 142496

(d) 142596

Ans. (a) 142296

16. A solid is hemispherical at the bottom and conical above it. The surface areas of the two parts are equal, then the ratio of its radius and the height of its conical part is

(a) 1:3

(b)  $1:\sqrt{3}$

(c) 1:1

(d)  $\sqrt{3}:1$

Ans. (b)  $1:\sqrt{3}$



**CBSE Class 10 Mathematics**  
**Important Questions**  
**Chapter 13**  
**Surface Areas and Volumes**

**2 Marks Questions**

Unless stated otherwise, take  $\pi = \frac{22}{7}$ .

1. 2 cubes each of volume  $64 \text{ cm}^3$  are joined end to end. Find the surface area of the resulting cuboid.

**Ans.** Abbreviation: CSA = Curved Surface Area TSA = Total Surface Area

V = Volume

Volume of cube = (Side)<sup>3</sup>

According to question, (Side)<sup>3</sup> = 64

$$\Rightarrow (\text{Side})^3 = 4^3$$

$$\Rightarrow \text{Side} = 4 \text{ cm}$$

For the resulting cuboid, length ( $l$ ) =  $4 + 4 = 8$  cm, breadth ( $b$ ) = 4 cm and height ( $h$ ) = 4 cm

Surface area of resulting cuboid =  $2(lb + bh + hl)$

$$= 2(8 \times 4 + 4 \times 4 + 4 \times 8)$$

$$= 2(32 + 16 + 32)$$

$$= 2 \times 80 = 160 \text{ cm}^2$$



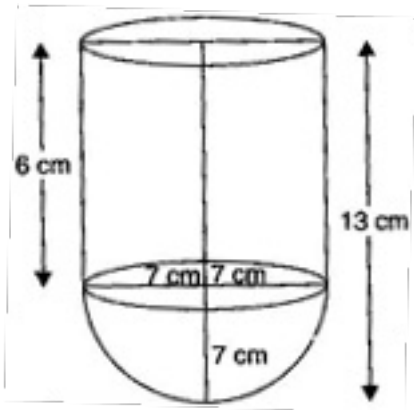

Unless stated otherwise, take  $\pi = \frac{22}{7}$ .

2. A solid is in the shape of a cone standing on a hemisphere with both their radii being equal to 1 cm and the height of the cone is equal to its radius. Find the volume of the solid in terms of  $\pi$ .

**Ans.** Abbreviation: CSA = Curved Surface Area TSA = Total Surface Area

V = Volume

**For hemisphere,** Radius ( $r$ ) = 1 cm

$$\text{Volume} = \frac{2}{3} \pi r^3 = \frac{2}{3} \pi (1)^3 = \frac{2}{3} \pi \text{ cm}^3$$

**For cone,** Radius of the base ( $r$ ) = 1 cm

Height ( $h$ ) = 1 cm

$$\begin{aligned} \text{Volume} &= \frac{1}{3} \pi r^2 h \\ &= \frac{1}{3} \pi (1)^2 \times 1 = \frac{1}{3} \pi \text{ cm}^3 \end{aligned}$$

$\therefore$  Volume of the solid = V of hemisphere + V of cone

$$= \frac{2}{3}\pi + \frac{1}{3}\pi = \pi \text{ cm}^3$$

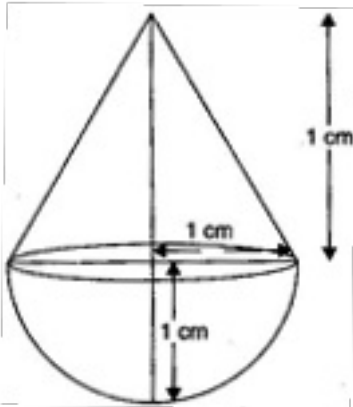

3. A pen stand made of wood is in the shape of a cuboid with four conical depressions to hold pens. The dimensions of the cuboid are 15 cm by 10 cm by 3.5 cm. The radius of each of the depressions is 0.5 cm and the depth is 1.4 cm. Find the volume of wood in the entire stand (see figure).

**Ans.** Volume of the cuboid =  $l \times b \times h$

$$= 15 \times 10 \times 3.5 = 525 \text{ cm}^3$$

Volume of conical depression =  $\frac{1}{3}\pi r^2 h$

$$= \frac{1}{3} \times \frac{22}{7} \times 0.5 \times 0.5 \times 1.4$$

$$= \frac{11}{30} \text{ cm}^3$$

$$\therefore \text{Volume of four conical depressions} = 4 \times \frac{11}{30} = 1.47 \text{ cm}^3$$

$$\therefore \text{Volume of the wood in the entire stand} = 525 - 1.47 = 523.53 \text{ cm}^3$$

Unless stated otherwise, take  $\pi = \frac{22}{7}$ .

4. A metallic sphere of radius 4.2 cm is melted and recast into the shape of a cylinder of



**radius 6 cm. Find the height of the cylinder.**

**Ans.** Abbreviation: CSA = Curved Surface Area TSA = Total Surface Area

V = Volume

**For sphere,** Radius ( $r$ ) = 4.2 cm

$$\text{Volume} = \frac{4}{3} \pi r^3 = \frac{4}{3} \pi (4.2)^3 \text{ cm}^3$$

**For cylinder,** Radius (R) = 6 cm

Let the height of the cylinder be H cm.

$$\text{Then, Volume} = \pi R^2 H = \pi (6)^2 H \text{ cm}^3$$

According to question, Volume of sphere = Volume of cylinder

$$\Rightarrow \frac{4}{3} \pi (4.2)^3 = \pi (6)^2 H$$

$$\Rightarrow H = \frac{4(4.2)^3}{3(6)^2}$$

$$\Rightarrow H = 2.74 \text{ cm}$$

**5. Metallic spheres of radii 6 cm, 8 cm and 10 cm respectively are melted to form a single solid sphere. Find the radius of the resulting sphere.**

**Ans.** Let the volume of resulting sphere be  $r$  cm.

According to question,

$$\frac{4}{3} \pi r^3 = \frac{4}{3} \pi (6)^3 + \frac{4}{3} \pi (8)^3 + \frac{4}{3} \pi (10)^3$$

$$\Rightarrow r^3 = (6)^3 + (8)^3 + (10)^3$$

$$\Rightarrow r^3 = 216 + 512 + 1000$$

$$\Rightarrow r^3 = 1728$$

$$\Rightarrow r = 12 \text{ cm}$$



**6. A 20 m deep well with diameter 7 m is dug and the earth from digging is evenly spread out to form a platform 22 m by 14 m. Find the height of the platform.**

**Ans.** Diameter of well = 7 m

$$\therefore \text{Radius of well } (r) = \frac{7}{2} \text{ m}$$

And Depth of earth dug ( $h$ ) = 20 m

Length of platform ( $l$ ) = 22 m, Breadth of platform ( $b$ ) = 14 m

Let height of the platform be  $h'$  m

According to question,

Volume of earth dug = Volume of platform

$$\Rightarrow \pi r^2 h = l \times b \times h'$$

$$\Rightarrow \frac{22}{7} \times \frac{7}{2} \times \frac{7}{2} \times 20 = 22 \times 14 \times h'$$

$$\Rightarrow h' = \frac{22 \times 7 \times 7}{7 \times 2 \times 2 \times 22 \times 14}$$

$$\Rightarrow h' = 2.5 \text{ m}$$

**7. A well of diameter 3 m is dug 14 m deep. The earth taken out of it has been spread evenly all around it in the shape of a circular ring of width 4 m to form an embankment. Find the height of the embankment.**

**Ans.** Diameter of well = 3 m

$$\therefore \text{Radius of well } (r) = \frac{3}{2} \text{ m}$$

and Depth of earth dug ( $h$ ) = 14 m

Width of the embankment = 4 m

$$\therefore \text{Radius of the well with embankment } r' = \frac{3}{2} + 4 = \frac{11}{2} \text{ m}$$

Let the height of the embankment be  $h'$  m

According to the question,

Volume of embankment = Volume of the earth dug

$$\Rightarrow \pi \left[ (r')^2 - r^2 \right] h' = \pi r^2 h$$

$$\Rightarrow \left[ \left( \frac{11}{2} \right)^2 - \left( \frac{3}{2} \right)^2 \right] h' = \left( \frac{3}{2} \right)^2 \times 14$$

$$\Rightarrow \left[ \frac{121}{4} - \frac{9}{4} \right] h' = \frac{9}{4} \times 14$$

$$\Rightarrow \frac{112}{4} \times h' = \frac{9}{4} \times 14$$

$$\Rightarrow h' = \frac{9 \times 14 \times 4}{4 \times 112}$$

$$\Rightarrow h' = 1.125 \text{ m}$$

**8. A container shaped like a right circular cylinder having diameter 12 cm and height 15 cm is full of ice cream. The ice cream is to be filled into cones of height 12 cm and diameter 6 cm, having a hemispherical shape on the top. Find the number of such cones which can be filled with ice cream.**

**Ans. For right circular cylinder,** Diameter = 12 cm

$$\therefore \text{Radius } (r) = \frac{12}{2} = 6 \text{ cm and height } (h) = 15 \text{ cm}$$

**For cone,** Diameter = 6 cm

$$\therefore \text{Radius } (r_1) = \frac{6}{2} = 3 \text{ cm and height } (h_1) = 12 \text{ cm}$$

Let  $n$  cones be filled with ice cream.

Then, According to question,

Volume of  $n$  cones = Volume of right circular cylinder

$$\Rightarrow n \cdot \frac{1}{3} \pi r_1^2 h_1 = \pi r^2 h$$

$$\Rightarrow n \times \frac{1}{3} \times \frac{22}{7} \times (3)^2 \times 12 = \frac{22}{7} (6)^2 \times 15$$

$$\Rightarrow n = \frac{22 \times 6 \times 6 \times 15 \times 3 \times 7}{7 \times 22 \times 3 \times 3 \times 12}$$

$$\Rightarrow n = 15$$

**9. How many silver coins, 1.75 cm in diameter and of thickness 2 mm, must be melted to form a cuboid of dimensions 5.5 cm x 10 cm x 3.5 cm?**

**Ans. For silver coin,** Diameter = 1.75 cm

$$\therefore \text{Radius } (r) = \frac{1.75}{2} = \frac{7}{8} \text{ cm and Thickness } (h) = 2 \text{ mm} = \frac{1}{5} \text{ cm}$$

**For cuboid,** Length ( $l$ ) = 5.5 cm, Breadth ( $b$ ) = 10 cm and Height ( $h'$ ) = 3.5 cm

Let  $n$  coins be melted.

Then, According to question,

Volume of  $n$  coins = Volume of cuboid

$$\Rightarrow n \times \pi r^2 h = l \times b \times h'$$

$$\Rightarrow n \times \pi \left(\frac{7}{8}\right)^2 \times \left(\frac{1}{5}\right) = 5.5 \times 10 \times 3.5$$

$$\Rightarrow n \times \frac{22}{7} \times \frac{49}{64} \times \frac{1}{5} = 5.5 \times 10 \times 3.5$$

$$\Rightarrow n = \frac{5.5 \times 10 \times 3.5 \times 7 \times 64 \times 5}{22 \times 49}$$

$$\Rightarrow n = 400$$

Unless stated otherwise, take  $\pi = \frac{22}{7}$ .

10. A drinking glass is in the shape of a frustum of a cone of height 14 cm. The diameters of its two circular ends are 4 cm and 2 cm. Find the capacity of the glass.

**Ans.** Abbreviation: CSA = Curved Surface Area

TSA = Total Surface Area

V = Volume

Here,  $r_1 = \frac{4}{2} = 2$  m,  $r_2 = \frac{2}{2} = 1$  m and  $h = 14$  m

$\therefore$  Capacity of the glass =  $\frac{1}{3} \pi h (r_1^2 + r_2^2 + r_1 r_2)$

$$= \frac{1}{3} \times \frac{22}{7} \times 14 (2 \times 2 + 1 \times 1 + 2 \times 1)$$

$$= \frac{1}{3} \times \frac{22}{7} \times 14 \times 7$$

$$= \frac{308}{3} = 102 \frac{2}{3} \text{ cm}^2$$

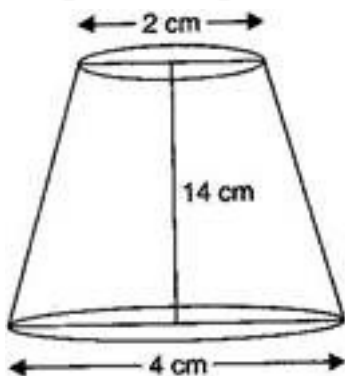

11. The slant height of a frustum of a cone is 4 cm and the perimeters (circumference) of its circular ends are 18 cm and 6 cm. Find the curved surface area of the frustum.

**Ans.** Let  $r_1$  cm and  $r_2$  cm be the radii of the ends ( $r_1 > r_2$ ) of the frustum of the cone.

Then,  $l = 4$  cm

$$2\pi r_1 = 18 \text{ cm}$$

$$\Rightarrow \pi r_1 = 9 \text{ cm}$$

$$2\pi r_2 = 6 \text{ cm}$$

$$\Rightarrow \pi r_2 = 3 \text{ cm}$$

Now, CSA of the frustum =  $\pi(r_1 + r_2)l$

$$= (\pi r_1 + \pi r_2)l = (9 + 3) \times 4 = 48 \text{ cm}^2$$

12. A fez, the cap used by the Turks, is shaped like the frustum of a cone (see figure). If its radius on the open side is 10 cm, radius at the upper base is 4 cm and its slant height is 15 cm, find the area of material used for making it.

Ans. Here,  $r_1 = 10 \text{ cm}$ ,  $r_2 = 4 \text{ cm}$  and  $l = 15 \text{ cm}$

$$\therefore \text{Surface area} = \pi(r_1 + r_2)l + \pi r_2^2$$

$$= \frac{22}{7}(10 + 4) \times 15 + \frac{22}{7}(4)^2$$

$$= 660 + \frac{352}{7}$$

$$= \frac{4972}{7} = 710\frac{2}{7} \text{ cm}^2$$

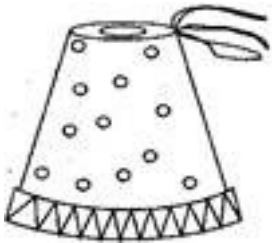

13. A container, opened from the top and made up of a metal sheet, is in the form of a frustum of a cone of height 16 cm with radii of its lower and upper ends as 8 cm and 20 cm respectively. Find the total cost of milk which can completely fill the container at the rate of Rs. 20 per liter. Also find the cost of metal sheet used to make the container,



if it costs Rs. 8 per 100 cm<sup>2</sup>. (Take  $\pi = 3.14$ )

**Ans.** Here,  $r_1 = 20$  cm,  $r_2 = 8$  cm and  $h = 16$  cm

$$\begin{aligned}\therefore \text{Volume of container} &= \frac{1}{3} \pi h (r_1^2 + r_2^2 + r_1 r_2) \\ &= \frac{1}{3} \times 3.14 \times 16 \times (20)^2 \left\{ (20)^2 + (8)^2 + 20 \times 8 \right\} \\ &= \frac{1}{3} \times 3.14 \times 16 (400 + 64 + 160) \\ &= \frac{1}{3} \times 3.14 \times 16 \times 624 \\ &= 10449.92 \text{ cm}^3 = 10.44992 \text{ liters}\end{aligned}$$

$$\therefore \text{Cost of the milk} = 10.44992 \times 20 = \text{Rs. } 208.8894 = \text{Rs. } 209$$

$$\begin{aligned}\text{Now, surface area} &= \pi (r_1 + r_2) l + \pi r_2^2 \\ &= \pi (r_1 + r_2) \sqrt{h^2 + (r_1 - r_2)^2} + \pi r_2^2 \\ &= 3.14 (20 + 8) \sqrt{(16)^2 + (20 - 8)^2} + 3.14 (8)^2 \\ &= 3.14 \times 28 \sqrt{256 + 144} + 3.14 \times 64 \\ &= 1158.4 + 200.96 \\ &= 1959.36 \text{ cm}^2\end{aligned}$$

$$\therefore \text{Area of the metal sheet used} = 1959.36 \text{ cm}^2$$

$$\therefore \text{Cost of metal sheet} = 1959.36 \times \frac{8}{100} = 156.7488 = \text{Rs. } 156.75$$

**14.** A copper wire, 3 mm in diameter is wound about a cylinder whose length is 12 cm and diameter 10 cm, so as to cover the curved surface of the cylinder. Find the length and mass of the wire, assuming the density of copper to be 8.88 g per cm<sup>3</sup>.

**Ans.** Abbreviation: CSA = Curved Surface Area

TSA = Total Surface Area

V = Volume

Number of rounds to cover 12 cm, i.e. 120 mm =  $\frac{120}{3} = 40$

Here, Diameter = 10 cm, Radius ( $r$ ) =  $\frac{10}{2}$  cm

Length of the wire in completing one round =  $2\pi r = 2\pi \times 5 = 10\pi$  cm

Length of the wire in completing 40 rounds =  $10\pi \times 40 = 400\pi$  cm

Radius of the copper wire =  $\frac{3}{2}$  mm =  $\frac{3}{20}$  cm

$\therefore$  Volume of wire =  $\pi \left(\frac{3}{20}\right)^2 (400\pi) = 9\pi \text{ cm}^3$

$\therefore$  Mass of the wire =  $9 \times (3.14)^2 \times 8.88 = 787.98$  g

**15. A right triangle, whose sides are 3 cm and 4 cm (other than hypotenuse) is made to revolve about its hypotenuse. Find the volume and surface area of the double cone so formed. (Choose value of  $\pi$  as found appropriate)**

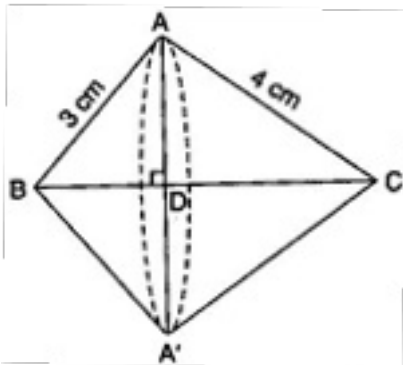

**Ans.** Hypotenuse =  $\sqrt{3^2 + 4^2} = 5$  cm

In figure,  $\triangle ADB \sim \triangle CAB$  [AA similarity]



$$\therefore \frac{AD}{CA} = \frac{AB}{CB}$$

$$\Rightarrow \frac{AD}{4} = \frac{3}{5}$$

$$\Rightarrow AD = \frac{12}{5} \text{ cm}$$

$$\text{Also, } \frac{DB}{AB} = \frac{AB}{CB}$$

$$\Rightarrow \frac{DB}{3} = \frac{3}{5}$$

$$\Rightarrow DB = \frac{9}{5} \text{ cm}$$

$$\therefore CD = BC - DB = 5 - \frac{9}{5} = \frac{16}{5} \text{ cm}$$

$$\text{Volume of the double cone} = \frac{1}{3} \pi \left( \frac{12}{5} \right)^2 \left( \frac{9}{5} \right) + \frac{1}{3} \pi \left( \frac{12}{5} \right)^2 \left( \frac{16}{5} \right)$$

$$= \frac{1}{3} \times 3.14 \times \frac{12}{5} \times \frac{12}{5} \times 5 = 30.14 \text{ cm}^3$$

$$\text{Surface area of the double cone} = \pi \times \frac{12}{5} \times 3 + \pi \times \frac{12}{5} \times 4$$

$$= \pi \times \frac{12}{5} (3 + 4)$$

$$= 3.14 \times \frac{12}{5} \times 7$$

$$= 52.75 \text{ cm}^2$$

**16. A cistern, internally measuring 150 cm x 120 cm x 110 cm has 129600 cm<sup>3</sup> of water in it. Porous bricks are placed in the water until the cistern is full to the brim. Each brick absorbs one-seventeenth of its own volume of water. How many bricks can be put in**



**without overflowing the water, each brick being 22.5 cm x 7.5 cm x 6.5 cm?**

**Ans.** Volume of cistern =  $150 \times 120 \times 110 = 1980000 \text{ cm}^3$

Volume of water =  $129600 \text{ cm}^3$

$\therefore$  Volume of cistern to be filled =  $1980000 - 129600 = 1850400 \text{ cm}^3$

Volume of a brick =  $22.5 \times 7.5 \times 6.5 = 1096.875 \text{ cm}^3$

Let  $n$  bricks be needed.

Then, water absorbed by  $n$  bricks =  $n \times \frac{1096.875}{17} \text{ cm}^3$

$\therefore n = \frac{1850400 \times 17}{16 \times 1096.875} = 1792$  (approx.)

**17. In one fortnight of a given month, there was a rainfall of 10 cm in a river valley. If the area of the valley is  $97280 \text{ km}^2$ , show that the total rainfall was approximately equivalent to the addition to the normal water of three rivers each 1072 km long, 75 m wide and 3 m deep.**

**Ans.** Volume of rainfall =  $97280 \times \frac{10}{100 \times 1000}$

=  $9.728 \text{ km}^3$

Volume of three rivers =  $3 \times 1072 \times \frac{75}{1000} \times \frac{3}{1000}$

=  $0.7236 \text{ km}^3$

Hence, the two are not approximately equivalent.

**18. An oil funnel made of tin sheet consists of a 10 cm long cylindrical portion attached to a frustum of a cone. If the total height is 22 cm, diameter of the cylindrical portion is 8 cm and the diameter of the top of the funnel is 18 cm, find the area of the tin sheet required to make the funnel (see figure).**

**Ans.** Slant height of the frustum of the cone  $(l) = \sqrt{h^2 + (r_1 - r_2)^2}$

$$= \sqrt{(22-10)^2 + \left(\frac{18}{2} - \frac{8}{2}\right)^2} = 13 \text{ cm}$$

Area of the tin sheet required = CSA of cylinder + CSA of the frustum

$$= 2\pi(4)(10) + \pi(4+9)13 = 80\pi + 169\pi$$

$$= 249\pi = 249 \times \frac{22}{7} = 782 \frac{4}{7} \text{ cm}^2$$

**19. Determine the ratio of the volume of a cube to that of a sphere which with exactly fit inside the cube.**

**Ans.** Let the radius of the sphere which fits exactly into a cube be  $r$  units. Then length of each edge of cube =  $2r$  units

Let  $V_1$  and  $V_2$  be the volumes of the cube and sphere

$$\text{Then } V_1 = (2r)^3$$

$$V_2 = \frac{4}{3}\pi r^3$$

$$\frac{V_1}{V_2} = \frac{8r^3}{\frac{4}{3}\pi r^3} = \frac{6}{\pi}$$

$$V_1 : V_2 = 6 : \pi$$

**20. Find the maximum volume of a cone that can be carved out of a solid hemisphere of radius  $r$ .**

**Ans.** Radius of cone = radius of hemisphere =  $r$

Height of cone = radius of hemisphere

$$\therefore \text{Volume of cone} = \frac{1}{3}\pi r^2 \times r = \frac{1}{3}\pi r^3$$

21. The height of a right circular cone is 12 cm and the radius of its base is 4.5 cm. Find its slant height.

Ans.  $h = 12 \text{ cm}$ ,  $r = 4.5 \text{ cm}$

$$\begin{aligned}\text{Slant height } l &= \sqrt{r^2 + h^2} = \sqrt{(4.5)^2 + 12^2} \\ &= \sqrt{20.25 + 144} = \sqrt{164.25} \\ &= 12.816 (\text{approx})\end{aligned}$$

22. How many balls, each of radius 1cm, can be made from a solid sphere of lead of radius 8 cm.

Ans. Number of balls =  $\frac{\text{Volume of sphere of radius 8 cm}}{\text{Volume of sphere of radius 1 cm.}}$

$$\begin{aligned}&= \frac{\frac{4}{3} \pi (8)^3}{\frac{4}{3} \pi (1)^3} = 512\end{aligned}$$

23. A drinking glass is in the shape of a frustum of a cone of height 14 cm. The diameter of its two circular ends are 4cm and 2cm. Find the capacity of the glass.  $\left( \pi = \frac{22}{7} \right)$

Ans.  $2r_1 = 2 \text{ cm} \Rightarrow r_1 = 1 \text{ cm}$

$2r_2 = 4 \text{ cm} \Rightarrow r_2 = 2 \text{ cm}$

$h = 14 \text{ cm}$

$$\text{Capacity of glass} = \frac{\pi h}{3} [r_1^2 + r_2^2 + r_1 r_2]$$



$$\begin{aligned}
&= \frac{22}{7} \times \frac{14}{3} [1^2 + 2^2 + 1 \times 2] \\
&= \frac{44}{3} [1 + 4 + 2] = \frac{44}{3} \times 7 = \frac{308}{3} \\
&= 102 \frac{2}{3} \text{ cm}^3
\end{aligned}$$

**24. The diameter of a sphere is 6 cm. It is melted and drawn into a wire of diameter 2 cm. What is the length of wire?**

**Ans.** Radius of sphere  $r = 3 \text{ cm}$

$$\text{Volume of sphere} = \frac{4}{3} \pi r^3$$

$$= \frac{4}{3} \pi (3)^3 = 36 \pi \text{ cm}^3$$

Let length of the wire =  $l \text{ cm}$

$R$  = Radius of the wire =  $1 \text{ cm}$

$$\text{Volume of wire} = \pi R^2 h = \pi (1)^2 l = l \pi \text{ cm}^3$$

$$l \pi = 36 \pi \Rightarrow l = 36 \text{ cm}$$

**25. An iron pipe 20 cm long has exterior diameter equal to 25cm. If the thickness of the pipe is 1cm. Find the whole surface area of the pipe.**

**Ans.**  $R = 12.5 \text{ cm}$

$$r = 12.5 - 1 = 11.5 \text{ cm}$$

$$h = 20 \text{ cm}$$

$$\text{Total surface area of pipe} = 2\pi(R+r)(h+R-r)$$

$$= 2 \times \frac{22}{7} (12.5 + 11.5)(20 + 12.5 - 11.5) = 3168 \text{ cm}^2$$

**26. Find the ratio of the volumes of two circular cones. If  $r_1 : r_2 = 3 : 5$  and  $h_1 : h_2 = 2 : 1$ .**

**Ans.** Ratio of volumes of two cones



$$\begin{aligned}
&= \frac{\frac{1}{3}\pi r_1^2 h_1}{\frac{1}{3}\pi r_2^2 h_2} \\
&= \left(\frac{r_1}{r_2}\right)^2 \times \frac{h_1}{h_2} \\
&= \left(\frac{3}{5}\right)^2 \times \frac{2}{1} \\
&= \frac{9}{25} \times \frac{2}{1} = \frac{18}{25} = 18:25
\end{aligned}$$

27. A solid iron pole consists of a cylinder of height 110 cm and of base diameter 24 cm which is surmounted by a cone 9 cm high, find the mass of the pole. Given that 1 cm<sup>3</sup> of iron has 8g mass approx.  $\left[\pi = \frac{355}{113}\right]$

Ans. For cylinder  $r = \frac{12}{2} = 6 \text{ cm}$ ,  $h = 110 \text{ cm}$

For cone  $r = \frac{12}{2} = 6 \text{ cm}$ ,  $h = 9 \text{ cm}$

Volume of pipe = volume of cylindrical portion + volume of cone

$$\begin{aligned}
&= \pi r^2 h + \frac{\pi r^2 h}{3} = \pi(6)^2 110 + \frac{\pi}{3}(6)^2 (9) \\
&= 36\pi(110 + 3) = 36 \times \frac{355}{113} \times 113 \\
&= 36 \times 355 = 12780 \text{ cm}^3
\end{aligned}$$

28. 2 cubes each of volume 64 cm<sup>3</sup> are joined end to end. Find the surface area of the resulting cuboid.

**Ans.** Two cubes joined end to end, we get cuboid

$$l = 4 + 4 = 8 \text{ cm}, b = 4 \text{ cm}, h = 4 \text{ cm}$$

$$\therefore \text{Surface area of cuboid} = 2[lb + bh + lh]$$

$$= 2[8 \times 4 + 4 \times 4 + 8 \times 4]$$

$$= 2[32 + 16 + 32]$$

$$= 2 \times 80 = 160 \text{ cm}^2$$

**29. Kuldeep made a bird bath for his garden in the shape of a cylinder with a hemispherical depression at one end. The height of the cylinder is 1.45 cm and its radius is 30 cm. Find the total surface area of the bird-bath.  $\left[ \pi = \frac{22}{7} \right]$**

**Ans.** Let  $h$  be the height of cylinder and  $r$  be the common radius of the cylinder and hemisphere.

Total surface area of bird bath = C.S.A. of cylinder + C.S.A. of hemisphere

$$= 2\pi rh + 2\pi r^2 = 2\pi r(h + r)$$

$$= 2 \times \frac{22}{7} \times 30(145 + 30) \text{ cm}^2$$

$$= 33000 \text{ cm}^2 = 3.3 \text{ m}^2$$

**30. A vessel is in the form of an inverted cone. Its height is 8 cm and radius of its top, which is open, is 5 cm it is filled with water up to brim. When lead shots each of which is a sphere of radius 0.5 cm, are dropped into the vessel. One-fourth of the water flows out. Find the number of lead shots dropped.**

**Ans.** Radius of lead shot = 0.5 cm

Radius of cone = 5 cm

Let  $x$  be numbers of lead shots are dropped



$$\therefore x \times \text{volume of one lead shot} = \frac{1}{4} \times \text{volume of the cone}$$

$$\Rightarrow x \times \frac{4}{3} \pi (0.5)^3 = \frac{1}{4} \times \frac{1}{3} \pi (5)^2 \times 8$$

$$\Rightarrow x = \frac{25 \times 8}{4 \times 4 (0.5)^3} = 100$$

100 lead shots are dropped

**31. A cone of height 24 cm and radius of base 6 cm is made up of modeling clay. Find the volume of the cone.**

**Ans.**  $h = 24 \text{ cm}$ ,  $r = 6 \text{ cm}$

$$\text{Volume of cone} = \frac{1}{3} \pi r^2 h$$

$$= \frac{1}{3} \pi (6)^2 (24)$$

$$= \frac{1}{3} \times 36 \times 24 \pi = 288 \pi \text{ cm}^3$$

**32. 2 cubes each of volume  $216 \text{ cm}^3$  are joined end to end. Find the surface area of the resulting cuboid.**

**Ans.** Two cubes joined end to end, we get cuboid

$$l = 6 + 6 = 12 \text{ cm}, b = 6 \text{ cm}, h = 6 \text{ cm}$$

$$\therefore \text{Surface area of cuboid} = 2[lb + bh + lh]$$





$$\begin{aligned}
 &= 2[12 \times 6 + 6 \times 6 + 6 \times 12] \\
 &= 2[72 + 36 + 72] \\
 &= 2 \times 180 = 360 \text{ cm}^2
 \end{aligned}$$

33. A vessel is in the form of a hollow hemisphere mounted by a hollow cylinder. The diameter of the hemisphere is 14cm and the total height of the Vessel is 13cm. Find inner surface area.

**Ans.** Inner surface area =  $2\pi rh + 2\pi r^2$

[∵ Radius of base of the cylinder = radius of hemisphere]

$$\begin{aligned}
 &= 2\pi r(h+r) = \frac{2 \times 22}{7} \times 7(6+7) \\
 &= 44 \times 13 = 572 \text{ cm}^2
 \end{aligned}$$

34. A spherical ball of diameter 21 cm is melted and recast into cubes each of side 1cm.

Find the number of cubes thus formed.  $\left(\pi = \frac{22}{7}\right)$

**Ans.** Volume of spherical ball =  $\frac{4}{3}\pi r^3$

$$= \frac{4}{3}\pi \times \frac{21}{2} \times \frac{21}{2} \times \frac{21}{2} \text{ cm}^3$$

Volume of each cube =  $1 \times 1 \times 1 \text{ cm}^3$

∴ Required number of cubes =  $\frac{\text{Volume of ball}}{\text{Volume of cube}}$

$$= \frac{\frac{4}{3} \times \frac{22}{7} \times \frac{21}{2} \times \frac{21}{2} \times \frac{21}{2}}{1}$$

= 4851



**CBSE Class 10 Mathematics**  
**Important Questions**  
**Chapter 13**  
**Surface Areas and Volumes**

**3 Marks Questions**

1. A vessel is in the form of a hollow hemisphere mounted by a hollow cylinder. The diameter of the hemisphere is 14 cm and the total height of the vessel is 13 cm. Find the inner surface area of the vessel.

**Ans.** ∵ Diameter of the hollow hemisphere = 14 cm

$$\therefore \text{Radius of the hollow hemisphere} = \frac{14}{2} = 7 \text{ cm}$$

Total height of the vessel = 13 cm

$$\therefore \text{Height of the hollow cylinder} = 13 - 7 = 6 \text{ cm}$$

∴ Inner surface area of the vessel

= Inner surface area of the hollow hemisphere + Inner surface area of the hollow cylinder

$$= 2\pi(7)^2 + 2\pi(7)(6) = 98\pi + 84\pi = 182\pi$$

$$= 182 \times \frac{22}{7} = 26 \times 22 = 572 \text{ cm}^2$$

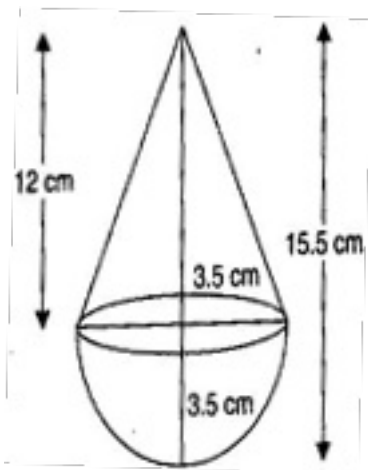

2. A toy is in the form of a cone of radius 3.5 cm mounted on a hemisphere of same radius. The total height of the toy is 15.5 cm. Find the total surface area of the toy.



**Ans.** Radius of the cone = 3.5 cm

∴ Radius of the hemisphere = 3.5 cm

Total height of the toy = 15.5 cm

∴ Height of the cone = 15.5 – 3.5 = 12 cm

Slant height of the cone =  $\sqrt{(3.5)^2 + (12)^2}$

$$= \sqrt{12.25 + 144}$$

$$= \sqrt{156.25} = 12.5 \text{ cm}$$

∴ TSA of the toy = CSA of hemisphere + CSA of cone

$$= 2\pi r^2 + \pi r l = 2\pi(3.5)^2 + \pi(3.5)(12.5)$$

$$= 24.5\pi + 43.75\pi = 68.25\pi = 68.25 \times \frac{22}{7} = 214.5 \text{ cm}^2$$

**3. A cubical block of side 7 cm is surmounted by a hemisphere. What is the greatest diameter the hemisphere can have? Find the surface area of the solid.**

**Ans.** Greatest diameter of the hemisphere = Side of the cubical block = 7 cm

∴ TSA of the solid = External surface area of the cubical block + CSA of hemisphere

$$= \left\{ 6(7)^2 - \pi\left(\frac{7}{2}\right)^2 \right\} + 2\pi\left(\frac{7}{2}\right)^2$$

$$= \left\{ 294 + \frac{49}{4}\pi \right\} + \frac{49}{2}\pi$$

$$= 294 + \frac{49}{4}\pi = 294 + \frac{49}{2} \times \frac{22}{7}$$

$$= 294 + \frac{77}{2} = 294 + 38.5 = 332.5 \text{ cm}^2$$

**4. A hemispherical depression is cut out from one face of a cubical wooden block such that the diameter  $l$  of the hemisphere is equal to the edge of the cube. Determine the surface area of the remaining solid**

**Ans.** ∵ Diameter of the hemisphere =  $l$ , therefore radius of the hemisphere =  $\frac{l}{2}$



Also, length of the edge of the cube =  $l$

$$\begin{aligned}\therefore \text{Surface area of the remaining solid} &= 2\pi\left(\frac{l}{2}\right)^2 + 6l^2 - \pi\left(\frac{l}{2}\right)^2 \\ &= \pi\left(\frac{l}{2}\right)^2 + 6l^2 = \frac{\pi l^2}{4} + 6l^2 = \frac{1}{4}l^2(\pi + 24)\end{aligned}$$

5. Rachel, an engineering student, was asked to make a model shaped like a cylinder with two cones attached at its two ends by using a thin aluminium sheet. The diameter of the model is 3 cm and its length is 12 cm. If each cone has a height of 2 cm, find the volume of air contained in the model that Rachel made. (Assume the outer and inner dimensions of the model to be nearly the same.)

**Ans.** For upper conical portion, Radius of the base ( $r$ ) = 1.5 cm

Height ( $h_1$ ) = 2 cm

$$\text{Volume} = \frac{1}{3}\pi r^2 h_1 = \frac{1}{3}\pi(1.5)^2 \times 2 = 1.5\pi \text{ cm}^3$$

For lower conical portion, Volume =  $1.5\pi \text{ cm}^3$

For central cylindrical portion

Radius of the base ( $r$ ) = 1.5 cm

Height ( $h_2$ ) =  $12 - (2 + 2) = 8$  cm

$$\text{Volume} = \pi r^2 h_2 = \pi(1.5)^2 \times 8 = 18\pi \text{ cm}^3$$

$\therefore$  Volume of the model =  $1.5\pi + 1.5\pi + 18\pi$

$$= 21\pi$$

$$= 21 \times \frac{22}{7} = 66 \text{ cm}^3$$



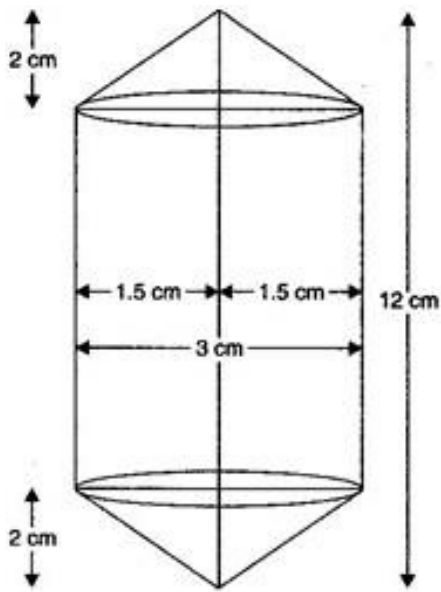

6. A *gulabjamun*, contains sugar syrup up to about 30% of its volume. Find approximately how much syrup would be found in 45 *gulab jamuns*, each shaped like a cylinder with two hemispherical ends, with length 5 cm and diameter 2.8 cm (see figure).

$$\text{Ans. Volume of a gulabjamun} = \frac{2}{3} \pi r^3 + \pi r^2 h + \frac{2}{3} \pi r^3$$

$$= \frac{2}{3} \pi (1.4)^3 + \pi (1.4)^2 \times 2.2 + \frac{2}{3} \pi (1.4)^3$$

$$= \frac{4}{3} \pi (1.4)^3 + \pi (1.4)^2 \times 2.2$$

$$= \pi (1.4)^2 \left[ \frac{4 \times 1.4}{3} + 2.2 \right]$$

$$= \pi \times 1.96 \left[ \frac{5.6 + 6.6}{3} \right] = \frac{1.96 \times 12.2}{3} \pi \text{ cm}^3$$

$$\therefore \text{Volume of 45 gulabjamuns} = 45 \times \frac{1.96 \times 12.2}{3} \pi$$

$$= 15 \times 1.96 \times 12.2 \times \frac{22}{7}$$

$$= 1127.28 \text{ cm}^3$$

$$\therefore \text{Volume of syrup} = 1127.28 \times \frac{30}{100}$$

$$= 338.184 \text{ cm}^3 = 338 \text{ cm}^3 \text{ (approx.)}$$

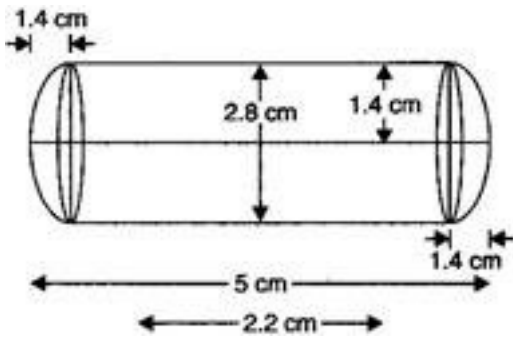

7. A vessel is in the form of inverted cone. Its height is 8 cm and the radius of the top, which is open, is 5 cm. It is filled with water up to the brim. When lead shots, each of which is a sphere of radius 0.5 cm are dropped into the vessel, one-fourth of the water flows out. Find the number of lead shots dropped in the vessel.

**Ans. For cone,** Radius of the top ( $r$ ) = 5 cm and height ( $h$ ) = 8 cm

$$\begin{aligned} \text{Volume of cone} &= \frac{1}{3} \pi r^2 h = \frac{1}{3} \pi (5)^2 \times 8 \\ &= \frac{200}{3} \pi \text{ cm}^3 \end{aligned}$$

**For spherical lead shot,** Radius ( $R$ ) = 0.5 cm

$$\begin{aligned} \text{Volume of spherical lead shot} &= \frac{4}{3} \pi R^3 = \frac{4}{3} \pi (0.5)^3 \\ &= \frac{\pi}{6} \text{ cm}^3 \end{aligned}$$

$$\begin{aligned} \text{Volume of water that flows out} &= \frac{1}{4} \text{ Volume of the cone} \\ &= \frac{1}{4} \times \frac{200\pi}{3} = \frac{50\pi}{3} \text{ cm}^3 \end{aligned}$$

Let the number of lead shots dropped in the vessel be  $n$ .

$$\begin{aligned} \therefore n \times \frac{\pi}{6} &= \frac{50\pi}{3} \\ \Rightarrow n &= \frac{50\pi}{3} \times \frac{6}{\pi} \\ \Rightarrow n &= 100 \end{aligned}$$

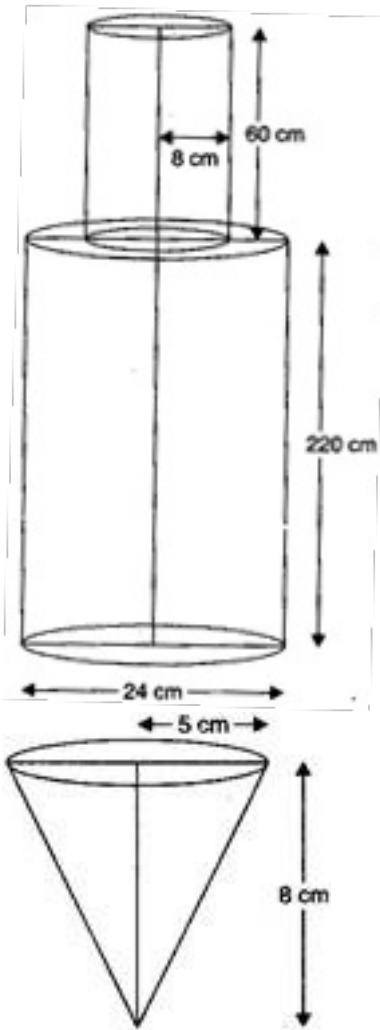

8. A solid iron pole consists of a cylinder of height 220 cm and base diameter 24 cm, which is surmounted by another cylinder of height 60 cm and radius 8 cm. Find the mass of the pole, given that  $1 \text{ cm}^3$  of iron has approximately 8 g mass. (Use  $\pi = 3.14$ )

Ans. For lower cylinder, Base radius ( $r$ ) =  $\frac{24}{2} = 12 \text{ cm}$

And Height ( $h$ ) = 220 cm

$$\text{Volume} = \pi r^2 h = \pi (12)^2 \times 220 = 31680\pi \text{ cm}^3$$

For upper cylinder, Base Radius ( $R$ ) = 8 cm

And Height ( $H$ ) = 60 cm

$$\text{Volume} = \pi R^2 H = \pi(8)^2 \times 60 = 3840\pi \text{ cm}^3$$

∴ Volume of the solid Iron pole = V of lower cylinder + V of upper cylinder

$$= 31680\pi + 3840\pi = 35520\pi$$

$$= 35520 \times 3.14 = 111532.8 \text{ cm}^3$$

9. A solid consisting of a right circular cone of height 120 cm and radius 60 cm standing on a hemisphere of radius 60 cm is placed upright in a right circular cylinder full of water such that it touches the bottom. Find the volume of water left in the cylinder, if the radius of the cylinder is 60 cm and its height is 180 cm.

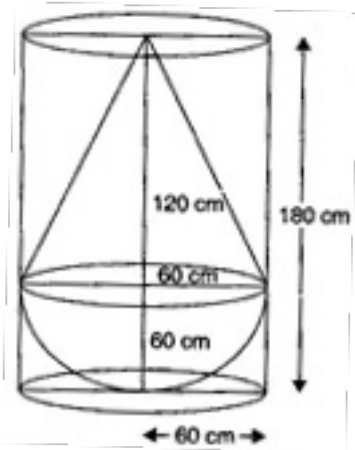

**Ans. For right circular cone,** Radius of the base ( $r$ ) = 60 cm

And Height ( $h_1$ ) = 120 cm

$$\text{Volume} = \frac{1}{3} \pi r^2 h_1 = \frac{1}{3} \pi (60)^2 \times 120 = 144000\pi \text{ cm}^3$$

**For Hemisphere,** Radius of the base ( $r$ ) = 60 cm

$$\text{Volume} = \frac{2}{3} \pi r^3 = \frac{2}{3} \pi (60)^3 = 144000\pi \text{ cm}^3$$

**For right circular cylinder,** Radius of the base ( $r$ ) = 60 cm

And Height ( $h_2$ ) = 180 cm

$$\text{Volume} = \pi r^2 h_2 = \pi (60)^2 \times 180 = 648000\pi \text{ cm}^3$$

Now, V of water left in the cylinder

$$= \text{V of right circular cylinder} - (\text{V of right circular cone} + \text{V of hemisphere})$$



$$\begin{aligned}
&= 648000\pi - (144000\pi + 144000\pi) \\
&= 360000\pi \text{ cm}^3 \\
&= \frac{360000}{100 \times 100 \times 100} \pi \text{ m}^3 \\
&= 0.36 \times \frac{22}{7} = 1.131 \text{ m}^3 \text{ (approx.)}
\end{aligned}$$

10. A spherical glass vessel has a cylindrical neck 8 cm long, 2 cm in diameter; the diameter of the spherical part is 8.5 cm. By measuring the amount of water it holds, a child finds its volume to be  $345 \text{ cm}^3$ . Check whether she is correct, taking the above as the inside measurements and  $\pi = 3.14$ .

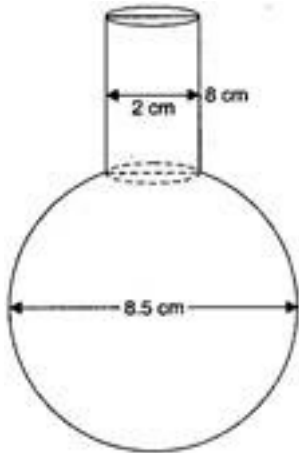

**Ans.** Amount of water it holds =  $\frac{4}{3} \pi r^3 + \pi r^2 h$

$$= \frac{4}{3} \pi \left( \frac{8.5}{2} \right)^3 + \pi \left( \frac{2}{2} \right)^2 \times 8$$

$$= \frac{4}{3} \times 3.14 \times 4.25 \times 4.25 \times 4.25 + 8 \times 3.14$$

$$= 321.39 + 25.12$$

$$= 346.51 \text{ cm}^3$$

Hence, she is not correct. The correct volume is  $346.51 \text{ cm}^3$ .

11. A cylindrical bucket, 32 cm and high and with radius of base 18 cm, is filled with sand. This bucket is emptied on the ground and a conical heap of sand is formed. If the height of the conical heap is 24 cm, find the radius and slant height of the heap.



**Ans. For cylindrical bucket,** Radius of the base ( $r$ ) = 18 cm and height ( $h$ ) = 32 cm

$$\therefore \text{Volume} = \pi r^2 h = \pi (18)^2 \times 32 = 10368\pi \text{ cm}^3$$

**For conical heap,** Height ( $h'$ ) = 24 cm

Let the radius be  $r_1$  cm.

$$\text{Then, Volume} = \frac{1}{3} \pi r_1^2 h' = \frac{1}{3} \times \pi \times r_1^2 \times 24 = 8\pi r_1^2 \text{ cm}^3$$

According to question, Volume of bucket = Volume of conical heap

$$\Rightarrow 10368\pi = 8\pi r_1^2$$

$$\Rightarrow r_1^2 = \frac{10368\pi}{8\pi} = 1296$$

$$\Rightarrow r_1 = 36 \text{ cm}$$

$$\text{Now, Slant height } (l) = \sqrt{(r_1)^2 + (h')^2}$$

$$= \sqrt{(36)^2 + (24)^2} = \sqrt{1296 + 576}$$

$$= \sqrt{1872} = 12\sqrt{13} \text{ cm}$$

**12. Water in a canal 6 m wide and 1.5 m deep is flowing with a speed of 10 km/h. How much area will it irrigate in 30 minutes, if 8 cm of standing water is needed?**

**Ans. For canal,** Width = 6 m and Depth = 1.5 m =  $\frac{3}{2}$  m

Speed of flow of water = 10 km/h = 10 x 1000 m/h = 10000 m/h

$$= \frac{10000}{60} \text{ m/min} = \frac{500}{3} \text{ m/min}$$

$$\therefore \text{Speed of flow of water in 30 minutes} = \frac{500 \times 30}{3} \text{ m/min}$$

$$\therefore \text{Volume of water that flows in 30 minutes} = 6 \times \frac{3}{2} \times 5000 = 45000 \text{ m}^3$$

$$\therefore \text{The area it will irrigate} = \frac{45000}{\left(\frac{8}{100}\right)} = \frac{4500000}{8} = 562500 \text{ m}^2$$



$$= \frac{562500}{10000} \text{ hectares} = 56.25 \text{ hectares}$$

13. A farmer connects a pipe of internal diameter 20 cm from a canal into a cylindrical tank in her field, which is 10 m in diameter and 2 m deep. If water flows through the pipe at the rate of 3 km/h, in how much time will the tank be filled?

Ans. For cylindrical tank, Diameter = 10 m

$$\therefore \text{Radius } (r) = \frac{10}{2} = 5 \text{ m and Depth } (h) = 2 \text{ m}$$

$$\therefore \text{Volume} = \pi r^2 h = \pi (5)^2 \times 2 = 50\pi \text{ m}^3$$

Rate of flow of water ( $h'$ ) = 3 km/h = 3000 m/h

$$= \frac{3000}{60} \text{ m/min} = 50 \text{ m/min}$$

For pipe, Internal diameter = 20 cm, therefore radius ( $r_1$ ) = 10 cm = 0.1 m

$$\therefore \text{Volume of water that flows per minute} = \pi (r_1)^2 h'$$

$$= \pi (0.1)^2 \times 50 = \frac{\pi}{2} \text{ m}^3$$

$$\therefore \text{Required time} = \frac{50\pi}{\pi/2} = 100 \text{ minutes}$$

14. A metallic right circular cone 20 cm high and whose vertical angle is  $60^\circ$  is cut into two parts at the middle of its height by a plane parallel to its base. If the frustum so obtained be drawn into a wire of diameter  $\frac{1}{16}$  cm, find the length of the wire.

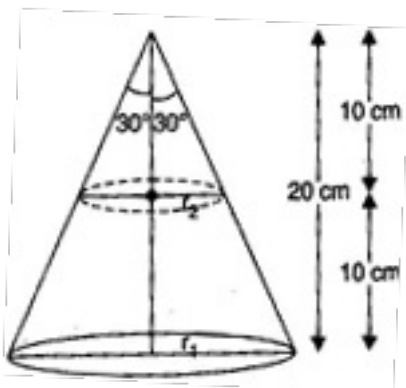

$$\text{Ans. } \tan 30^\circ = \frac{r_2}{10} \Rightarrow \frac{1}{\sqrt{3}} = \frac{r_2}{10}$$

$$\Rightarrow r_2 = \frac{10}{\sqrt{3}} \text{ cm}$$

$$\tan 30^\circ = \frac{r_1}{20} \Rightarrow \frac{1}{\sqrt{3}} = \frac{r_1}{20}$$

$$\Rightarrow r_1 = \frac{20}{\sqrt{3}} \text{ cm}$$

$$h = 10 \text{ cm}$$

$$\therefore \text{Volume} = \frac{1}{3} \pi h (r_1^2 + r_2^2 + r_1 r_2)$$

$$= \frac{1}{3} \times \frac{22}{7} \times 10 \left\{ \left( \frac{20}{\sqrt{3}} \right)^2 + \left( \frac{10}{\sqrt{3}} \right)^2 + \left( \frac{20}{\sqrt{3}} \right) \left( \frac{10}{\sqrt{3}} \right) \right\}$$

$$= \frac{1}{3} \times \frac{22}{7} \times 10 \times \left( \frac{400}{3} + \frac{100}{3} + \frac{200}{3} \right)$$

$$= \frac{1}{3} \times \frac{22}{7} \times 10 \times \frac{700}{3} = \frac{22000}{9} \text{ cm}^3$$

$$\text{Diameter of the wire} = \frac{1}{16} \text{ cm}$$

$$\therefore \text{Radius of the wire} = \frac{1}{32} \text{ cm}$$

Let the length of the wire be  $l$  cm.

$$\text{Then, Volume of the wire} = \pi r^2 l = \frac{22}{7} \left( \frac{1}{32} \right)^2 l$$

$$= \frac{11l}{3584} \text{ cm}^3$$

According to the question,

$$\frac{11l}{3584} = \frac{22000}{9}$$

$$\Rightarrow l = \frac{22000 \times 3584}{11 \times 9}$$

$$\Rightarrow l = \frac{2000 \times 3584}{9}$$

$$\Rightarrow l = 796444.44 \text{ cm} = 7964.4 \text{ m}$$

**15. The diameter of metallic sphere is 6 cm. The sphere is melted and drawn into a wire of uniform cross section. If the length of wire is 36 cm, find its radius.**

**Ans.** Diameter of sphere = 6 cm

$$\therefore r = 3 \text{ cm}$$

$$\text{Volume} = \frac{4}{3} \pi r^3 = \frac{4}{3} \pi (3)^3 = 36 \pi \text{ cm}^3$$

Let  $r_1$  be radius of wire

$$\text{Volume of wire} = \frac{4}{3} \pi r_1^3 = \frac{4}{3} \pi (3)^3 = 36 \pi \text{ cm}^3$$

$$\Rightarrow \pi r_1^3 \times 36 = 36 \pi$$

$$\Rightarrow r_1^3 = 1$$

$$\Rightarrow r_1 = 1 \text{ cm}$$

**16. Water flows at the rate of 10 metre per minute through a cylindrical pipe having its diameter 5 mm. How much time will it take to fill a conical vessel where diameter of base is 40 cm and depth 24 cm?**

**Ans.** We have volume of the water that flows out in one minute

= Volume of cylinder of diameter 5 mm and length 10 m.

$$r = \frac{5}{2} \text{ mm} = \frac{1}{4} \text{ cm}$$

$$h = 1000 \text{ cm}$$

$$\text{Volume of cylinder} = \frac{22}{7} \times \frac{1}{4} \times \frac{1}{4} \times 1000 \text{ cm}^3$$

Volume of conical vessel  $r = 20 \text{ cm}$  and  $h = 24 \text{ cm}$



$$= \frac{1}{3} \times \frac{22}{7} \times (20)^2 \times 24 \text{ cm}^3$$

Suppose the conical vessel is filled in x minutes

∴ Volume of the water flows out in x minutes

= Volume of conical vessel

$$\Rightarrow \frac{22}{7} \times \frac{1}{4} \times \frac{1}{4} \times 100 \times x = \frac{1}{3} \times \frac{22}{7} \times 20^2 \times 24$$

$$\Rightarrow x = \frac{1}{3} \times \frac{400 \times 24 \times 4 \times 4}{100} = \frac{512}{10} \text{ Minutes}$$

$$\Rightarrow x = 51 \text{ Minutes } 12 \text{ seconds}$$

**17. The radius of the base and the height of solid right cylinder are in the ratio 2:3 and its volume is 1617 cu.cm. Find the total surface area of the cylinder.  $\left[ \pi = \frac{22}{7} \right]$**

**Ans.** Let r be the radius of the base and h be the height of the solid right circular cylinder.

$$\therefore \frac{r}{h} = \frac{2}{3} \Rightarrow r = \frac{2h}{3}$$

$$\text{Volume of the cylinder} = \pi r^2 h = \pi \frac{4}{9} h^2 \cdot h = 1617$$

$$\Rightarrow h^3 = \frac{9}{4} \times \frac{1617}{22} \times 7 = \frac{9}{4} \times \frac{147 \times 7}{2}$$

$$\Rightarrow h = \frac{21}{2}$$

$$\text{Surface area of cylinder} = 2\pi r h + 2\pi r^2$$

$$= 2\pi \times \frac{2h}{3} \times h + \frac{2\pi 4h^2}{9}$$

$$= \frac{\pi h^2}{9} [12 + 8] = \frac{20\pi h^2}{9}$$

$$= \frac{20\pi}{9} \times \frac{21}{2} \times \frac{21}{2} = 5 \times 22 \times 7 = 770 \text{ cm}^2$$

18. A toy is in form of a cone mounted on a hemisphere of common base radius 7 cm. The total height of the toy is 31 cm, find the total surface area of the toy.

Ans. Total surface area of toy = C.A.S. of hemisphere + C.S.A. of cone

$$= 2\pi r^2 + \pi r l$$

Here,  $r = 7 \text{ cm}$ ,  $h = 24 \text{ cm}$

$$\therefore l = \sqrt{r^2 + h^2} = \sqrt{7^2 + 24^2} = 25 \text{ cm}$$

$$\begin{aligned} \text{T.S.A. of toy} &= 2 \times \frac{22}{7} \times 7 \times 7 + \frac{22}{7} \times 7 \times 25 \\ &= 308 + 550 = 858 \text{ cm}^2 \end{aligned}$$

19. A well 3.5 m in diameter and 20 m deep be dug in rectangular field 20 m by 14 m. The earth taken out is spread evenly on the field. Find the level of the earth raised in the field.

Ans. Radius of well =  $\frac{7}{4} \text{ m}$

Depth of well = 20 m

$$\therefore \text{Volume of earth taken out} = \frac{22}{7} \times \frac{7}{4} \times \frac{7}{4} \times 20 \text{ m}^3 = \frac{385}{2} \text{ m}^3$$

$$\text{Area of field} = 20 \text{ m} \times 14 \text{ m} = 280 \text{ m}^2$$

$$\text{Area of field excluding well} = \left( 280 - \frac{22}{7} \times \frac{7}{4} \times \frac{7}{4} \right) \text{ m}^2 = \frac{2163}{8} \text{ m}^2$$

$$\therefore \text{Level of earth raised} = \frac{\text{volume of earth taken out}}{\text{Area of field}}$$

$$= \frac{385}{2} \times \frac{8}{2163} \text{ m} = 0.7119 \text{ m}$$

$$= 71.19 \text{ cm}$$

20. A solid sphere of radius 6 cm is melted into a hollow cylinder of uniform thickness. If the external radius of the base of cylinder is 5 cm and its height is 32 cm, find the uniform thickness of the cylinder.

**Ans.** Volume of sphere =  $\frac{4}{3} \pi r^3$

=  $\frac{4}{3} \pi (6)^3 = 288 \pi \text{ cm}^3$

Let the internal radius of cylinder  $r = x \text{ cm}$

External radius  $R = 5 \text{ cm}$

Volume =  $\pi(R^2 - r^2)h = \pi(5^2 - x^2)32$

Volume of the hollow cylinder = Volume of sphere

$\Rightarrow 32(25 - x^2) \pi = 288 \pi$

$\Rightarrow 25 - x^2 = \frac{288}{32}$

$\Rightarrow 25 - x^2 = 9$

$\Rightarrow x^2 = 16$

$\Rightarrow x = 4 \text{ cm}$

**21. A medicine capsule is in the shape of a cylinder with two hemispheres stuck at each of its ends. The length of the entire capsule is 14 mm and the diameter of the capsule is 5 mm. Find its surface area.**

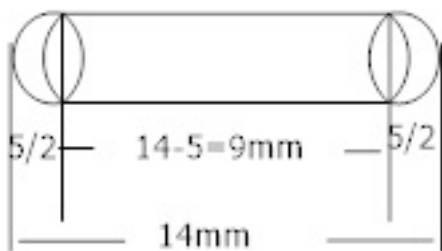

**Ans.** Uniform thickness of cylinder =  $5 - 4 = 1 \text{ cm}$

The length of capsule = 14 mm

$r = \frac{5}{2} \text{ mm}$

Length of cylindrical portion of capsule =  $14 - 5 = 9 \text{ mm}$

Total surface area =  $2 \pi r^2 + 2 \pi r h + 2 \pi r^2$

=  $4 \pi r^2 + 2 \pi r h$

=  $4 \times \frac{22}{7} \times \left(\frac{5}{2}\right)^2 + 2 \times \frac{22}{7} \times \frac{5}{2} \times 9$



$$= \frac{550}{7} + \frac{990}{7} = \frac{1540}{7} = 220 \text{mm}^2$$

22. A pen stand made of wood is in the shape of a cuboid with four conical depression to hold pens. The dimensions of the cuboid are 15 cm by 10 cm by 3.5 cm. The radius of each of the dimensions is 0.5 cm and the depth is 1.4 cm. Find the volume of the wood in the entire stand.

**Ans.** Required volume = volume of cuboids – 4 [V. of one depression]

$$= 15 \times 10 \times 3.5 - 4 \times \frac{2}{3} \times \left(\frac{1}{2}\right)^2 (1.4)$$

$$= \frac{150 \times 35}{10} - \frac{8}{3} \times \frac{22}{7} \times \frac{1.4}{4}$$

$$= 525 - 2.93 = 522.07 \text{cm}^3$$

23. A medicine capsule is in the shape of a cylinder with two hemispheres stuck to each of its ends. The length of the entire capsule is 14 mm and the diameter of the capsule is 5 mm. Find its surface area.

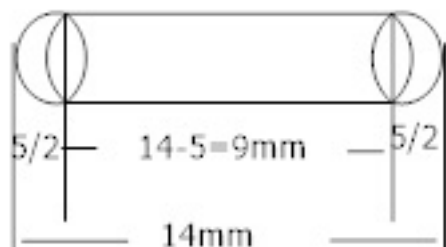

**Ans.** The length of capsule = 14 mm

$$r = \frac{5}{2} \text{mm}$$

Length of cylindrical portion of capsule = 14 – 5 = 9 mm

$$\text{Total surface area} = 2\pi r^2 + 2\pi r h + 2\pi r^2$$

$$= 4\pi r^2 + 2\pi r h$$

$$= 4 \times \frac{22}{7} \times \left(\frac{5}{2}\right)^2 + 2 \times \frac{22}{7} \times \frac{5}{2} \times 9$$

$$= \frac{550}{7} + \frac{990}{7} = \frac{1540}{7} = 220 \text{ mm}^2$$

24. A spherical glass vessel has a cylindrical neck 8 cm long, 2 cm in diameter, the diameter of the spherical part 8.5 cm. by measuring the amount of water it holds, a child finds its volume to be  $345 \text{ cm}^3$  check whether she is correct, taking the above as side measurements.  $[\pi = 3.14]$

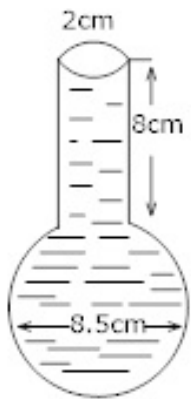

**Ans.** For cylindrical part

$$r = \frac{2}{2} \text{ cm} = 1 \text{ cm}, h = 8 \text{ cm}$$

For spherical part:

$$\text{Radius (R)} = \frac{8.5}{2} = \frac{17}{4} \text{ cm}$$

Volume of glass solid = Volume of cylindrical part + Volume of the spherical part

$$= \pi r^2 h + \frac{4}{3} \pi R^3 = \pi \left[ r^2 h + \frac{4}{3} R^3 \right]$$

$$\begin{aligned}
&= \frac{314}{100} \left[ 8 + \frac{4913}{48} \text{ cm}^3 \right] \\
&= \frac{314}{100} \left[ \frac{384 + 4913}{48} \right] \text{ cm}^3 \\
&= \frac{314 \times 5294}{4800} = \frac{1663258}{4800} \text{ cm}^3 \\
&= 346.51 \text{ cm}^3
\end{aligned}$$

**25. Metallic sphere of radii 6 cm, 8 cm and 10 cm respectively are melted to form a single solid sphere. Find the radius of the resulting sphere.**

**Ans.** Sum of the volumes of three given spheres =  $\frac{4}{3} \pi [(6)^3 + (8)^3 + (10)^3]$

$$\begin{aligned}
&= \frac{4}{3} \pi [216 + 512 + 1000] \\
&= \frac{4}{3} \pi \times 1728 = 4\pi \times 576 \\
&= 2304\pi \text{ cm}^3
\end{aligned}$$

Let R be the radius of single solid sphere, since volume remains the same

$$\therefore \frac{4}{3} \pi R^3 = 2304\pi$$

$$\Rightarrow R^3 = \frac{2304 \times 3}{4} = 576 \times 3$$

$$\Rightarrow R^3 = 1728 = (12)^3$$

$$\therefore R = 12 \text{ cm}$$

**26. A shuttle cock used for playing badminton has the shape of a frustum of a cone mounted on a hemisphere. The external diameter of the frustum are 5 cm and 2 cm. The height of the entire shuttle cock is 7 cm. Find the external surface area.**

**Ans.** External surface area = C.S.A. of frustum of the cone + S.A. of hemisphere

$$\begin{aligned}
&= \pi[(r_1 + r_2)l + 2\pi r_1^2] \\
&= \pi[3.5](6.2) + 2\pi(1)^2 [r_1 = 1, r_2 = 2.5, h = 7 - 1 = 6\text{ cm}] \\
&= \frac{22}{7} \times \frac{35}{10} \times \frac{618}{100} + 2 \times \frac{22}{7} \\
&= \frac{11 \times 618}{100} + \frac{44}{7} \\
l &= \sqrt{h^2 + (r_1 - r_2)^2} \\
l &= \sqrt{6^2 + (1 - 2.5)^2} \\
&= 6.18 \\
&= 67.98 + 6.28 \\
&= 74.26\text{ cm}^2
\end{aligned}$$

**27. How many silver coins 1.75 cm in diameter and of thickness 2 mm must be melted to form a cuboid 5.5 cm × 10 cm × 3.5 cm?**

**Ans.** Volume of the cuboid =  $5.5 \times 10 \times 3.5 = \frac{385}{2}\text{ cm}^3$

Radius of the coin =  $r = \frac{1.75}{2} = 0.875\text{ cm}$

Thickness  $h = 2\text{ mm} = 0.2\text{ cm}$

Volume of one coin =  $\pi r^2 h = \frac{22}{7} \times 0.875 \times 0.875 \times 0.2$

∴ Required number of coins =  $\frac{\text{Volume of cuboid}}{\text{Volume of each coin}}$

$$= \frac{385 \times 1000 \times 1000 \times 10 \times 7}{2 \times 22 \times 875 \times 875 \times 2}$$

$$= \frac{35 \times 40 \times 40 \times 70}{4 \times 35 \times 35 \times 2} = 20 \times 20 = 400\text{ s}$$

28. A container like a right circular having diameter 12cm and height 15cm is full of ice-cream. The ice-cream is to be filled in cones of height 12cm and diameter 6cm having a hemispherical shape on the top. Find number of such cones which can be filled with ice-cream.

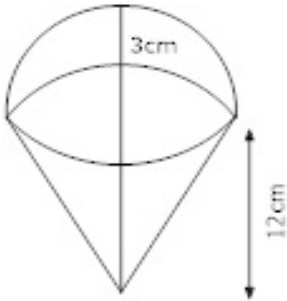

Ans. Volume of cylinder =  $\pi r^2 h$

$$= \pi \left( \frac{12}{2} \right)^2 \times 15 = 540\pi$$

Diameter of cone = 12 cm

$$\therefore r = 6 \text{ cm}$$

Volume of ice cream = Volume of ice-cream cone + Volume of hemispherical top of ice-cream

$$\begin{aligned} &= \frac{1}{3} \pi r^2 h + \frac{2}{3} \pi r^3 \\ &= \frac{\pi}{3} (3)^2 (12) + \frac{2}{3} \pi (3)^3 \\ &= 36\pi + 18\pi = 54\pi \end{aligned}$$

$$\text{Number of ice-Cream cones} = \frac{\text{Volume of cylinder}}{\text{V. of icecream cone} + \text{Volume of hemisph top}}$$

$$= \frac{540\pi}{54\pi} = 10 \text{ ice-cream cones}$$

29. Water flowing at the rate of 15 km per hour through a pipe of diameter 14cm into a rectangular tank which is 50m long and 44m wide. Find the time in which the level of water in the tank will rise by 21cm.

**Ans.** 1 Km = 1000 m

$$\therefore 15 \text{ km} = 15000 \text{ m}$$

Volume of cylinder =  $\pi r^2 h$

$$\text{Radius} = \frac{14}{2} = 7 \text{ cm} = \frac{7}{100} \text{ m}$$

Volume of water flowing through the cylindrical pipe in an hour at the rate of 15km/hr

$$= \frac{22}{7} \times \frac{7}{100} \times \frac{7}{100} \times 15000 = 231 \text{ m}^3$$

Volume of cuboid =  $lbh$

$\therefore$  Volume of required quantity of water in the tank

$$= 50 \times 44 \times \frac{21}{100} \left[ \because 21 \text{ cm} = \frac{21}{100} \text{ m} \right] = 462 \text{ m}^3$$

Since  $231 \text{ m}^3$  of water falls into tank in 1 hour

$$\therefore 462 \text{ m}^3 \text{ of water falls into tank in } = \frac{1}{231} \times 462 = 2 \text{ hours}$$

**30. A solid cylinder of diameter 12cm and height 15cm is melted and recast into toys with the shape of a right circular cone mounted on a hemisphere of radius 3cm. If the height of the toy is 12cm, find the number of toys so formed.**

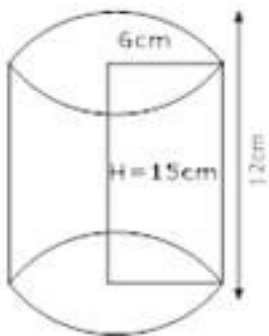

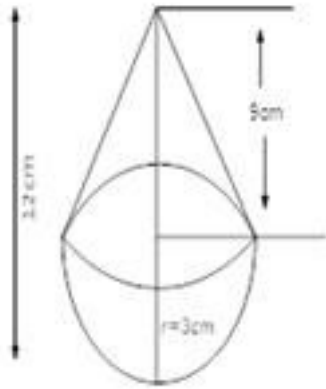

Ans. Number of toys =  $\frac{\text{Volume of the cylinder}}{\text{Volume of one toy}}$

$$= \frac{\pi R^2 H}{\frac{2}{3} \pi r^3 + \frac{1}{3} \pi r^2 h} = \frac{\pi R^2 H}{\frac{1}{3} \pi r^2 (2r + h)}$$

$$= \frac{6 \times 6 \times 15}{\frac{1}{3} \times 3 \times 3 (6 + 9)} = \frac{6 \times 6 \times 15}{3 \times 15} = 12$$

**CBSE Class 10 Mathematics**  
**Important Questions**  
**Chapter 13**  
**Surface Areas and Volumes**

**4 Marks Questions**

1. A medicine capsule is in the shape of a cylinder with two hemispheres stuck to each of its ends (see figure). The length of the entire capsule is 14 mm and the diameter of the capsule is 5 mm. Find its surface area.

Ans. Radius of the hemisphere =  $\frac{5}{2}$  mm

Let radius =  $r$  = 2.5 mm

Cylindrical height = Total height – Diameter of sphere =  $h$  = 14 – (2.5 + 2.5) = 9 mm

Surface area of the capsule = CSA of cylinder + Surface area of the hemisphere

$$\begin{aligned} &= 2\pi rh + 2(2\pi r^2) \\ &= 2\pi\left(\frac{5}{2}\right)(9) + 2\left\{2\pi\left(\frac{5}{2}\right)^2\right\} \\ &= 45\pi + 25\pi \\ &= 70\pi = 70 \times \frac{22}{7} = 220 \text{ mm}^2 \end{aligned}$$

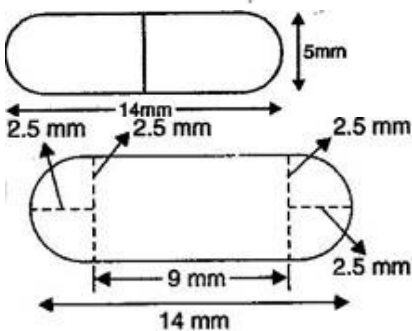



2. A tent is in the shape of a cylinder surmounted by a conical top. If the height and diameter of the cylindrical part are 2.1 m and 4 m respectively and the slant height of the top is 2.8 m, find the area of the canvas used for making the tent. Also, find the cost of the canvas of the tent at the rate of Rs. 500 per  $\text{m}^2$ . (Note that the base of the tent will not be covered with canvas.)

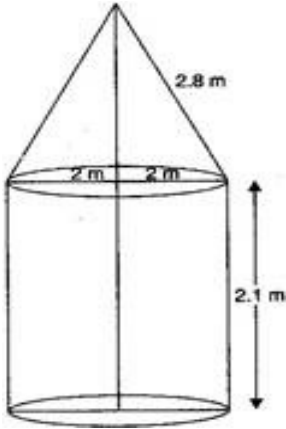

**Ans.** Diameter of the cylindrical part = 4 m

$\therefore$  Radius of the cylindrical part = 2 m

TSA of the tent = CSA of the cylindrical part + CSA of conical cap

$$= 2\pi(2)(2.1) + \pi(2)(2.8)$$

$$= 8.4\pi + 5.6\pi$$

$$= 14\pi$$

$$= 14 \times \frac{22}{7}$$

$$= 44 \text{ m}^2$$

$\therefore$  Cost of the canvas of the tent at the rate of Rs. 500 per  $\text{m}^2$

$$= 44 \times 500 = \text{Rs. } 22000$$

3. From a solid cylinder whose height is 2.4 cm and diameter 1.4 cm, a conical cavity of the same height and same diameter is hollowed out. Find the total surface area of the remaining solid to the nearest  $\text{cm}^2$ .

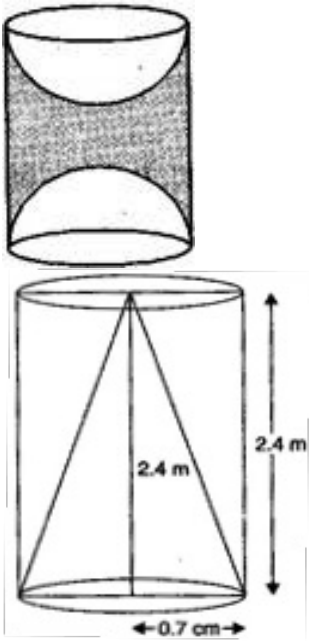

**Ans.** Diameter of the solid cylinder = 1.4 cm

∴ Radius of the solid cylinder = 0.7 cm

∴ Radius of the base of the conical cavity = 0.7 cm

Height of the solid cylinder = 2.4 cm

∴ Height of the conical cavity = 2.4 cm

∴ Slant height of the conical cavity =  $\sqrt{(0.7)^2 + (2.4)^2}$

$$= \sqrt{0.49 + 5.76}$$

$$= \sqrt{6.25} = 2.5 \text{ cm}$$

∴ TSA of remaining solid

$$= 2\pi(0.7)(2.4) + \pi(0.7)^2 + \pi(0.7)(2.5)$$

$$= 3.36\pi + 0.49\pi + 1.75\pi$$

$$= 5.6\pi$$

$$= 5.6 \times \frac{22}{7} = 17.6 \text{ cm}^2$$

$$= 18 \text{ cm}^2 \text{ (to the nearest cm}^2\text{)}$$

4. A wooden article was made by scooping out a hemisphere from each end of a solid cylinder as shown in figure. If the height of the cylinder is 10 cm and its base is of radius 3.5 cm, find the total surface area of the article.

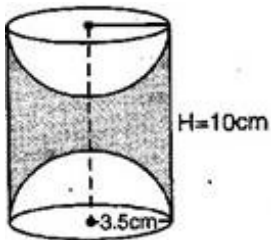

$$\text{Ans. TSA of the article} = 2\pi rH + 2(2\pi r^2)$$

$$= 2\pi(3.5)(10) + 2[2\pi(3.5)^2]$$

$$= 70\pi + 49\pi$$

$$= 119\pi$$

$$= 119 \times \frac{22}{7}$$

$$= 374 \text{ cm}^2$$

5. Derive the formula for the curved surface area and total surface area of the frustum of a cone, given to you in Section 13.5, using the symbols as explained.

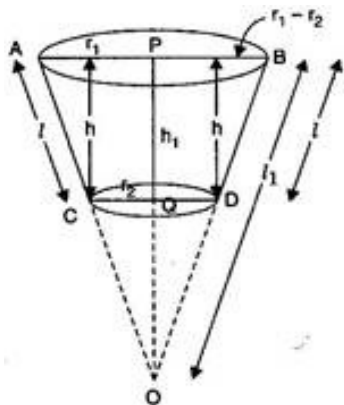

Ans. According to the question, the frustum is difference of the two cones OAB and OCD (in figure).



**For frustum**, height =  $h$ , slant height =  $l$  and radii of the bases =  $r_1$  and  $r_2$  ( $r_1 > r_2$ )

$$OP = h_1, OA = OB = l$$

$$\therefore \text{Height of the cone} = h_1 - h$$

$\therefore \triangle OQD \sim \triangle OPB$  [AA similarity]

$$\therefore \frac{h_1 - h}{h_1} = \frac{r_2}{r_1}$$

$$\Rightarrow 1 - \frac{h}{h_1} = \frac{r_2}{r_1}$$

$$\Rightarrow 1 - \frac{r_2}{r_1} = \frac{h}{h_1}$$

$$\Rightarrow h_1 = \frac{hr_1}{r_1 - r_2} \dots\dots\dots(i)$$

$$\therefore \text{height of the cone OCD} = h_1 - h$$

$$= \frac{hr_1}{r_1 - r_2} - h = \frac{hr_2}{r_1 - r_2} \dots\dots\dots(ii)$$

$\therefore V$  of the frustum =  $V$  of cone OAB –  $V$  of cone OCD

$$= \frac{1}{3} \pi r_1^2 h_1 - \frac{1}{3} \pi r_2^2 (h_1 - h)$$

$$= \frac{\pi}{3} \left[ r_1^2 \cdot \frac{hr_1}{r_1 - r_2} - r_2^2 \cdot \frac{hr_2}{r_1 - r_2} \right] \text{ [From eq. (i) \& (ii)]}$$

$$= \frac{\pi h}{3} \left( \frac{r_1^3 - r_2^3}{r_1 - r_2} \right)$$

$$= \frac{1}{3} \pi h (r_1^2 + r_2^2 + r_1 r_2)$$

If  $A_1$  and  $A_2$  are the surface areas of two circular bases, then

$$A_1 = \pi r_1^2 \text{ and } A_2 = \pi r_2^2$$

$$\therefore V \text{ of the frustum} = \frac{h}{3} \left( \pi r_1^2 + \pi r_2^2 + \sqrt{\pi r_1^2} \cdot \sqrt{\pi r_2^2} \right)$$

$$= \frac{h}{3} \left( A_1 + A_2 + \sqrt{A_1 A_2} \right)$$

Again, from  $\triangle DEB$ ,  $l = \sqrt{h^2 + (r_1 - r_2)^2}$

$\therefore \triangle OQD \sim \triangle OPB$  [AA similarity]

$$\therefore \frac{l_1 - l}{l_1} = \frac{r_2}{r_1} \Rightarrow l_1 = \frac{l r_1}{r_1 - r_2} \dots\dots\dots(\text{iii})$$

$$\therefore l_1 - l = \frac{l r_1}{r_1 - r_2} - l = \frac{l r_2}{r_1 - r_2} \dots\dots\dots(\text{iv})$$

Hence, CSA of the frustum of the cone =  $\pi r_1 l_1 - \pi r_2 (l_1 - l)$

$$= \pi r_1 \cdot \frac{l r_1}{r_1 - r_2} - \pi r_2 \frac{l r_2}{r_1 - r_2} \text{ [From eq. (i) and (ii)]}$$

$$= \pi l \left( \frac{r_1^2 - r_2^2}{r_1 - r_2} \right) = \pi l (r_1 + r_2), \text{ where } l = \sqrt{h^2 + (r_1 - r_2)^2}$$

$$\therefore \text{TSA of the frustum of the cone} = \pi l (r_1 + r_2) + \pi r_1^2 + \pi r_2^2$$

**6. A bucket made up of metal sheet is in the form of frustum of a cone. Its depth is 24 cm and the diameters of the top and bottom are 30 cm and 10 cm respectively. Find the cost of milk which will completely fill the bucket at the rate Rs. 20 per litre and cost of metal**

sheet used if it costs Rs. 10 per 100 cm<sup>2</sup>. (use  $\pi = 3.14$ )

$$\text{Ans. } h = 24 \text{ cm, } r_1 = \frac{30}{2} = 15 \text{ cm, } r_2 = \frac{10}{2} = 5 \text{ cm}$$

$$l = \sqrt{h^2 + (r_1 - r_2)^2} = \sqrt{24^2 + (15 - 5)^2}$$
$$= \sqrt{576 + 100} = \sqrt{676} = 26 \text{ cm}$$

$$\text{(i) Volume of bucket} = \frac{1}{3} \pi h (r_1^2 + r_2^2 + r_1 r_2)$$

$$= \frac{1}{3} \times 3.14 \times 24 (15^2 + 5^2 + 15 \times 5)$$

$$= 3.14 \times 8 (225 + 25 + 75) = 8164 \text{ cm}^3$$

$$\therefore \text{Quantity of milk} = \frac{8164}{1000} = 8.164 \text{ litres}$$

Cost of 1 litre of milk = Rs.20

$$\therefore \text{Cost of 8.164 litres milk} = \text{Rs. } 20 \times 8.14$$

$$= \text{Rs. } 163.28$$

**(ii)** T.S.A. of bucket (excluding the upper end)

$$= \pi l (r_1 + r_2) + \pi r_2^2 = 3.14 \times 26 (15 + 5) + 3.14 \times 5^2$$

$$= 1632.8 + 78.5 = 1711.3 \text{ cm}^2$$

Cost of 100 cm<sup>2</sup> metal sheet = Rs.10

$$\therefore \text{Cost of } 1711.3 \text{ cm}^2 \text{ metal sheet} = \frac{1711.3 \times 10}{100} = \text{Rs. } 171.13$$

**7. A solid consisting of a right circular cone standing on a hemisphere, is placed upright in a right circular cylinder, full of water and touches the bottom. Find the volume of water left in the cylinder having given that the radius of the cylinder is 3cm and its height is 6cm. The radius of hemisphere is 2cm and the height of the cone is 4cm. Give**



your answer to the nearest cubic centimeters.  $\left(\pi = \frac{22}{7}\right)$

**Ans.** Volume of cylinder =  $\pi(3)^2 6 = 54\pi$

Volume of cone =  $\frac{1}{3}\pi(2)^2 4 = \frac{16}{3}\pi$

Volume of hemisphere =  $\frac{1}{2} \times \frac{4}{3}\pi(2)^3 = \frac{16}{3}\pi$

∴ Volume of water in the cylinder

$$= 54\pi - \frac{16}{3}\pi - \frac{16}{3}\pi$$

$$= \left(\frac{162 - 16 - 16}{3}\right)\pi \text{ cm}^3 = \frac{162 - 32}{3}\pi \text{ cm}^3$$

$$= \frac{2860}{21}\text{ cm}^3 = 136\frac{4}{21}\text{ cm}^3$$

$$= 136\text{ cm}^3$$

**8. A farmer connects a pipe of internal diameter 20cm from a canal into a cylindrical tank in his field which is 10m in diameter and 2m deep. If water flows through the pipe at the rate of 3 km/h, in how much time will the tank be filled?**

**Ans.** Rate of water flowing =  $\frac{3000}{60 \times 60} \text{ m/sec} = \frac{5}{6} \text{ m/sec}$

In 1 second the water flows =  $\frac{5}{6} \text{ m}$

Internal diameter =  $20\text{ cm} = \frac{1}{5} \text{ m}$

Volume of the water that flows through the pipe in one second =  $\pi r^2 h$

$$= \frac{22}{7} \times \left(\frac{1}{10}\right)^2 \times \frac{5}{6} = \frac{110}{4200} = \frac{11}{420} \text{ m}^3$$

Volume of water in the tank =  $\pi r^2 h \left[ r = \frac{10}{2} = 5\text{ m}, h = 2\text{ m} \right]$



$$= \frac{22}{7} \times \left(\frac{10}{2}\right)^2 \times 2$$

$$= \frac{1100}{7} m^3$$

$$\therefore \text{Time taken to fill the tank} = \frac{\frac{100}{7}}{\frac{11}{420}}$$

$$= \frac{1100 \times 420}{7 \times 11} = 100 \times 60 \text{ seconds}$$

$$= 100 \text{ minutes} = 1 \text{ hour } 40 \text{ minutes}$$

9. A cone of radius 10cm divided into two parts by drawing a plane through the mid-point of its axis, parallel to its base. Compare the volume of the two parts.

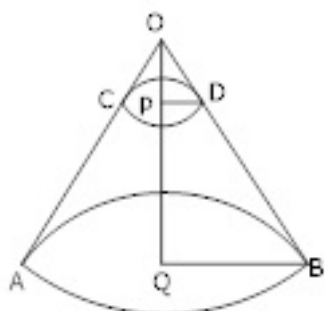

**Ans.** Let OAB be the cone and OQ be its axis and P be the mid-point of OQ

Let OQ = h cm

$$\text{Then } OP = PQ = \frac{h}{2} \text{ cm}$$

And QB = 10cm

Also  $\triangle OPD \sim \triangle OQB$

$$\therefore \frac{OP}{OQ} = \frac{PD}{QB} = \frac{h/2}{h} = \frac{PD}{10 \text{ cm}}$$

$$\Rightarrow PD = 5 \text{ cm}$$

(i) A smaller cone of radius = 5cm and height = h/2cm





(ii) Frustum of a cone in which

$$R = 10\text{cm}, r = 5\text{cm}, \text{height} = \left(\frac{h}{2}\right)\text{cm}$$

$$\text{Volume of smaller cone} = \frac{1}{3} \pi 5 \times 5 \times \frac{h}{2} = \frac{25\pi h}{6} \text{cm}^3$$

$$\text{Volume of frustum of the cone} = \frac{1}{3} \pi \frac{h}{2} [(10)^2 + (5)^2 + 10 \times 5] \text{cm}^3$$

$$= \left(\frac{175\pi h}{6}\right) \text{cm}^3$$

$$\text{Ratio of required volume} = \frac{25\pi h}{6} : \frac{175\pi h}{6}$$

$$= 25 : 175 = 1 : 7$$

